

CENTURY®

LEGENDARY LEADERSHIP



OWNER'S MANUAL

3224T

INSTALLATION, OPERATION, MAINTENANCE & PARTS

NOTE: MANUAL including SPECIFICATIONS, subject to change without notice
All ratings specified are based on structural factors only,
not vehicle capacities or capabilities.

CENTURY®

Miller Industries Towing Equipment Inc.
8503 Hilltop Drive
Ooltewah, Tennessee 37363

FORM NO. 0500798

06 / 96

Phone (423) 238-4171 • FAX (423) 238-5371

PRICE \$25.00

LIMITED WARRANTY

MILLER INDUSTRIES TOWING EQUIPMENT INC., hereinafter referred to as MILLER, warrants to the original purchaser that each new MILLER wrecker or other MILLER products will be free from defects in material and workmanship for a period of twelve (12) months from date placed in service, but in no event shall such warranty period exceed twenty-four (24) months from date of manufacture by MILLER. The purchaser must promptly notify MILLER in writing of any failure in material or workmanship. In no event shall MILLER accept such notification later than twenty-four (24) months from date of delivery or twelve (12) months from date placed in service, whichever is earlier.

MILLER's obligation under this warranty, statutory or otherwise, is limited to the repair or replacement at the MILLER factory, or at a point designated by MILLER, of such part or parts as shall appear upon inspection by MILLER to be defective in material or workmanship. New or remanufactured parts will be used for any replacement at MILLER's option. This warranty is not transferable. This warranty does not obligate MILLER to bear the cost of labor or transportation charges in connection with the repair or replacement of any parts found to be defective, nor shall it apply to a product upon which repairs or alterations have been made unless authorized by MILLER.

EXCEPT AS EXPRESSLY SET FORTH IN THIS WARRANTY, MILLER MAKES NO OTHER WARRANTY, EXPRESS OR IMPLIED, AND HEREBY DISCLAIMS ALL OTHER WARRANTIES INCLUDING, BUT NOT LIMITED TO, THE IMPLIED WARRANTIES OF MERCHANTABILITY AND FITNESS FOR A PARTICULAR PURPOSE. MILLER shall in no event be liable for claimed downtime, claimed loss of profits or goodwill, or any other special, incidental, indirect, or consequential damages concerning or relating to any product or parts, whether based on negligence, strict liability, breach of contract, breach of warranty, misrepresentation or any other legal theory, regardless of whether the loss resulted from any general or particular requirement which MILLER knew or had reason to know about at the time of sale.

MILLER MAKES NO WARRANTY, EXPRESS OR IMPLIED, AS TO THE FINISHED PRODUCTS MANUFACTURED OR SUPPLIED BY ANOTHER MANUFACTURER AND SUPPLIED BY MILLER TO PURCHASER, including, but not limited to, any vehicle to which a MILLER product may be affixed or any accessories or wire rope, and MILLER EXPRESSLY DISCLAIMS ANY IMPLIED WARRANTIES OF MERCHANTABILITY OR FITNESS FOR A PARTICULAR PURPOSE AS TO SUCH EQUIPMENT OR PRODUCTS. This language shall in no way affect or diminish the rights of the purchaser to rely on such warranties as are extended by such manufacturers or suppliers. MILLER shall, to the extent permitted under applicable law, pass on to the purchaser such manufacturer's or seller's warranty.

MILLER, whose policy is one of continuous improvement, reserves the right to improve its products through changes in design or materials as it may deem desirable without being obligated to incorporate such changes in products previously sold. This warranty is not intended to cover or include the following items, which are set forth by way of example and not limitation:

- A. Normal deterioration of trim, paint, lettering, and appearance items due to wear or exposure to weather, road conditions, road treatments, etc.
- B. Any damage or defect due to accident, misuse, abuse, improper or unauthorized repairs, failure to provide reasonable and necessary maintenance, or uses for which the equipment was not designed or intended.
- C. Alterations or modifications that affect performance, operation or reliability.
- D. Normal maintenance parts including, but not limited to, wear pads, bushings, wire rope, mud flaps, fenderettes, light bulbs, hydraulic oil, filters, and tow sling belts.

IT IS EXPRESSLY UNDERSTOOD THAT MILLER MAKES NO IMPLIED WARRANTY THAT MILLER PRODUCTS SHALL BE FIT FOR THE PURPOSE OF LIFTING OR MOVING PEOPLE OR FOR ANY OTHER IMPROPER USE.



Miller Industries Towing Equipment Inc.
8503 Hilltop Drive
Ooltewah, Tennessee 37363

Telephone (423) 238-4171

SERIAL NUMBER

Section VI - PARTS

This Section is provided by the manufacturer for the purpose of ordering any component part of the **3224 Wrecker / Integrated Underlift** that may be required when part replacement is necessary. Be certain to use only original equipment replacement parts for warranty purposes as well as for keeping your **3224 Wrecker / Integrated Underlift** in its original state and optimum operating capacities.

When ordering replacement or spare parts be sure to provide the following information to the manufacturer's **Parts Department**.

- 1. Manual Number & Date of Publication**
- 2. Manual Page Number**
- 3. Page Title**
- 4. Reference Number of Part Desired**
- 5. Part Number**
- 6. Part Description**
- 7. Quantity of Part Desired**

Providing this information will help ensure that the correct parts will be delivered to you in an expedient manner without delay. Should additional information be required for repair or replacement of certain components, contact your Wrecker Manufacturer Authorized Representative.

The Manufacturer reserves the right, without notice or obligation, to improve or modify their products, which may change the specifications, models and feature availability.

Section VI - PARTS (cont'd)
SUBFRAME ASSEMBLY

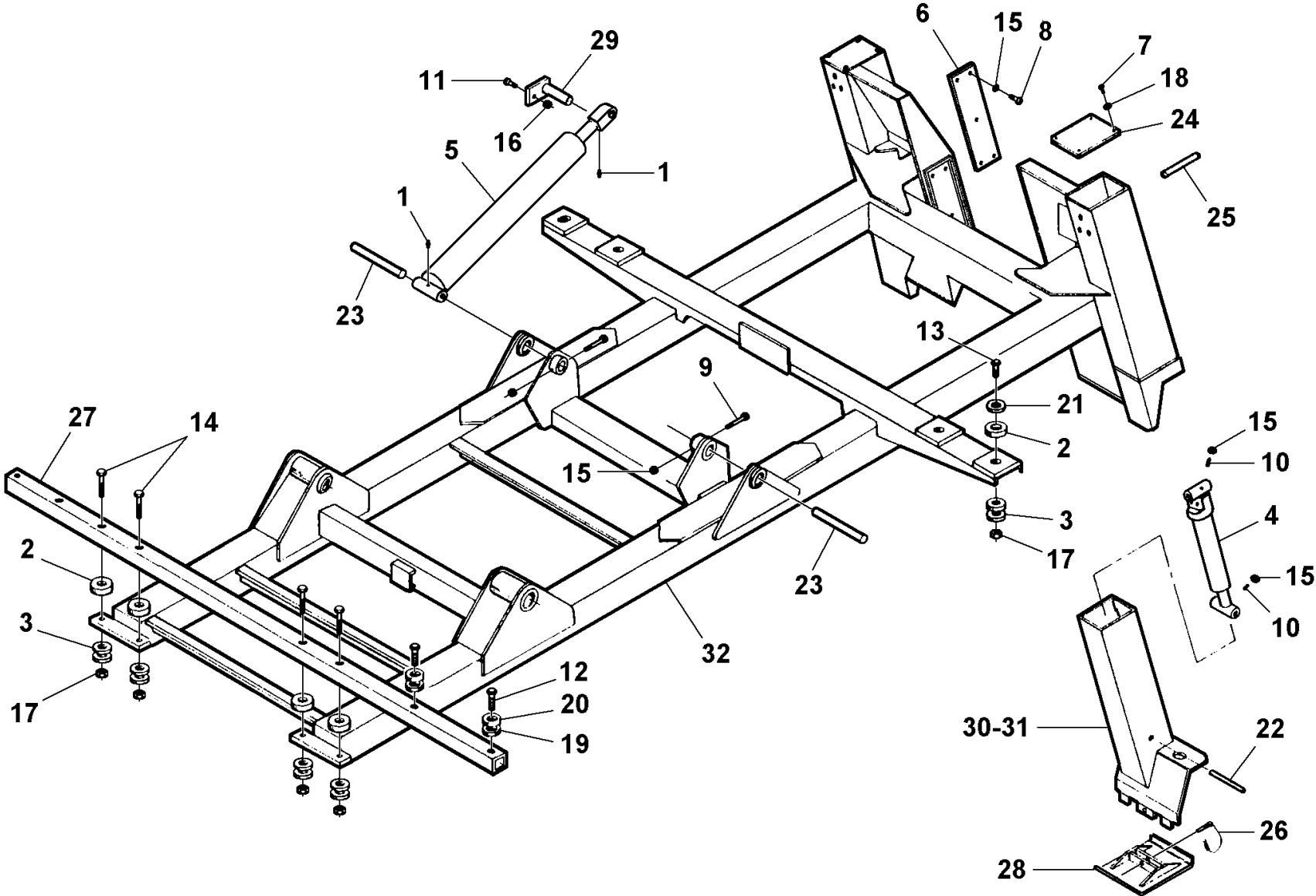

Section VI - PARTS (cont'd)

SUBFRAME ASSEMBLY

REF. NO.	NO. REQ	PART NUMBER	DESCRIPTION
1	4	0300113	GREASE FITTING
2	8	0302540	CENTER BONDED MOUNT
3	12	0302541	SPECIAL WASHER
4	REF.	0302616	SPADE CYLINDER
5	REF.	0303091	BOOM LIFT CYLINDER
6	2	0303140	RAMP PAD
7	8	0400066	SCREW, 1/4"-20 X 3/4" HEX HD CAP
8	10	0400128	SCREW, 3/8"-16 X 1-1/4" FL HD SKT
9	2	0400130	SCREW, 3/8"-16 X 3-1/2" HEX HD CAP
10	4	0400139	SCREW, 3/8"-16 X 1-1/2" HEX SKT SET
11	2	0400181	SCREW, 1/2"-13 X 1-1/2" HEX HD CAP
12	4	0400276	SCREW, 5/8"-11 X 4-1/2" HEX HD CAP
13	4	0400281	SCREW, 3/4"-10 X 3-1/2" HEX HD CAP
14	4	0400294	SCREW, 3/4"-10 X 6-1/2" HEX HD CAP
15	16	0400392	NUT, 3/8"-16 NYLOK HEX
16	4	0400408	NUT, 1/2"-13 NYLOK HEX
17	4	0400430	NUT, 3/4"-10 NYLOK HEX
18	8	0400452	LOCKWASHER, 1/4" HELICAL
19	8	0400506	WASHER, 5/8" FLAT
20	4	0400508	LOCKWASHER, 5/8" HELICAL
21	8	0400510	WASHER, 3/4" FLAT
22	2	0705500	SHAFT, LOWER SPADE
23	2	0707341	PIN, LIFT CYLINDER
24	2	0707377	COVER, SPADE TUBE
25	2	0707394	SHAFT, UPPER SPADE
26	--	0707199	PIN, SPADE PAD
--	4	0301551	CABLE SLEEVE, 1/16"
--	4	0301553	1/16" CABLE ASSEMBLY, 17"
--	2	0302474	PIN, LYNCH
--	4	0400044	DRIVE SCREW, # 10 X 1/2" RD HD
--	2	0400563	ROLL PIN, 3/16" X 1-3/4"
--	4	0702604	PROTECTIVE HOSE TUBE, 14"
27	1	0802211	FRONT BODY MOUNTING TUBE
28	2	0802221	SPADE PAD
29	2	0802240	PIVOT PIN, LIFT CYLINDER
30	1	0802243	INNER SPADE, LEFT
31	1	0802244	INNER SPADE, RIGHT
32	1	0802863	3224 SUBFRAME WELDMENT
33	--	0903136	SAFETY CHAIN ASSEMBLY (NOT SHOWN)
--	2	0303096	SAFETY CHAIN
--	2	0400211	SCREW, 1/2"-13 X 1-3/4" HEX HD CAP
--	2	0400408	NUT, 1/2"-13 NYLOK HEX
--	2	0400492	WASHER, 1/2" FLAT

Section VI - PARTS (cont'd)

BODY ASSEMBLY

Section VI - PARTS (cont'd)
BODY ASSEMBLY

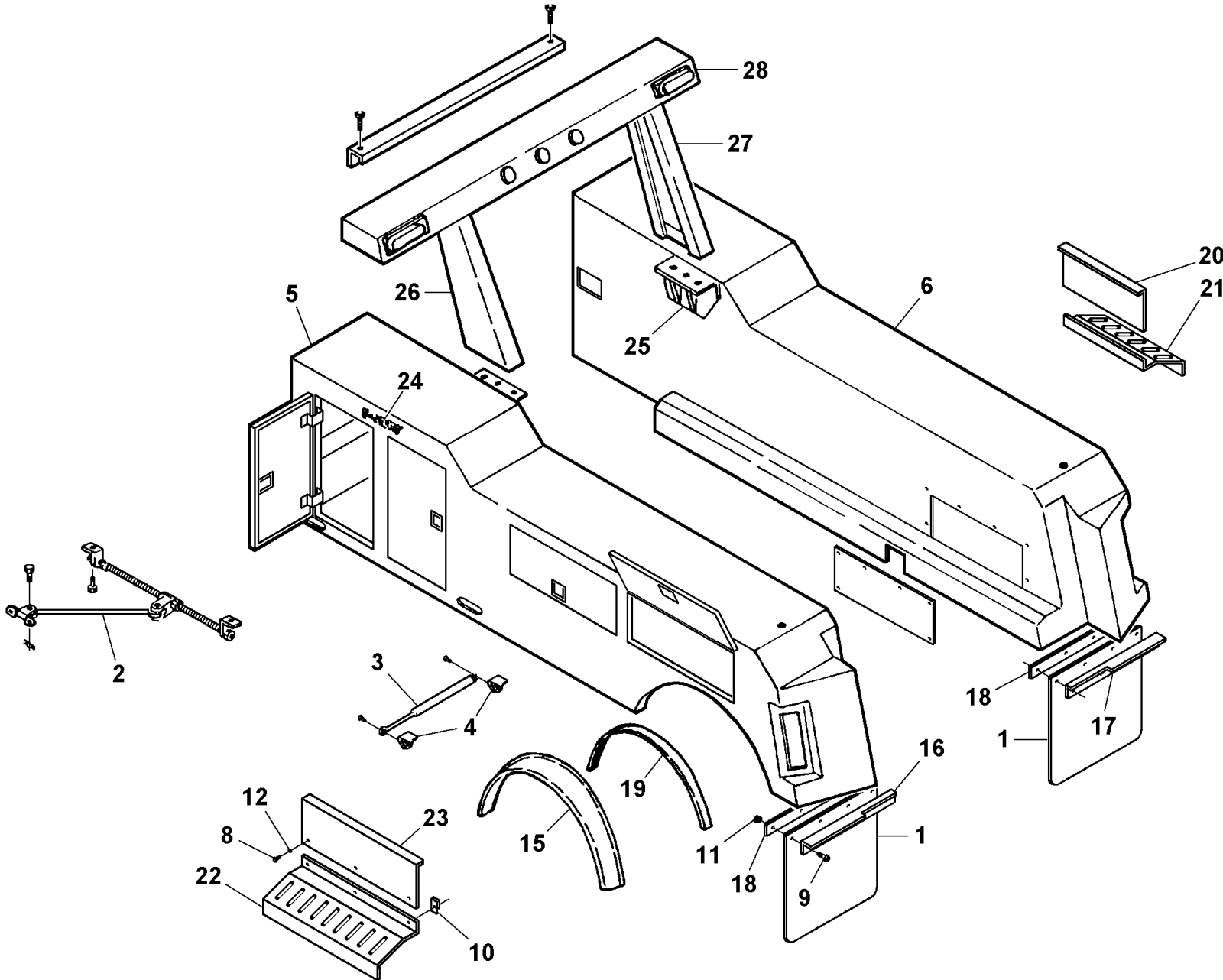

Section VI - PARTS (cont'd)

BODY ASSEMBLY

REF. NO.	NO. REQ'D	PART NUMBER	DESCRIPTION
1	2	0301223	MUDFLAP
2	4	0301912	DOOR CHECK, 11"
3	4	0302571	GAS SPRING CYLINDER
4	8	0302572	"L" BRACKET
5	1	0302612	BODY SIDE, 120" C.A., LEFT
6	1	0302613	BODY SIDE, 120" C.A., RIGHT
7	1	0303061	BACK UP ALARM (NOT SHOWN)
8	8	0400066	SCREW, 1/4"-20 X 3/4" HEX HD CAP
9	8	0400122	SCREW, 3/8"-16 X 1-1/4" HEX HD CAP
10	6	0400369	CLIP, 1/4" TINNERMAN
11	8	0400392	NUT, 3/8"-16 NYLOK HEX
12	6	0400451	WASHER, 1/4" FLAT
13	8	0400452	LOCKWASHER, 1/4" HELICAL
14	40	0400566	RIVET, 1/4"
15	2	0704047	RUBBER FENDER
16	1	0705090	ANGLE, MUDFLAP MOUNTING, LEFT
17	1	0705091	ANGLE, MUDFLAP MOUNTING, RIGHT
18	2	0705092	BAR, MUDFLAP
19	2	0706609	RETAINING STRIP, RUBBER FENDER
20	1	0711289	PANEL, SWITCH
21	1	0711290	PANEL, CONTROL
22	1	0711292	PANEL, CONTROL
23	1	0711344	PANEL, GAUGE

REF. NO.	NO. REQ'D	PART NUMBER	DESCRIPTION
24	1	0901496	CENTURY NAMEPLATE KIT
--	--	0902328	BODY MOUNTING KIT (NOT SHOWN)
--	28	0400288	SCREW, 3/4"-10 X 2-1/2" HEX HD CAP
--	28	0400431	NUT, 3/4"-10 NYLOK HEX
--	2	0707174	ANGLE, TAILGATE MOUNTING
--	2	0711257	MOUNTING PLATE
--	--	124001727	STANDARD LIGHT BAR
--	2	0301706	LIGHT BAR GASKET
--	4	0400126	SCREW, 3/8"-16 X 1" HEX HD CAP
--	12	0400177	SCREW, 1/2"-13 X 1-1/4" HEX HD CAP
--	6	0400181	SCREW, 1/2"-13 X 1-1/2" HEX HD CAP
--	4	0400392	NUT, 3/8"-16 NYLOK HEX
--	18	0400408	NUT, 1/2"-13 NYLOK HEX
--	12	0400492	WASHER, 1/2" FLAT
25	2	0802254	MOUNTING ANGLE
26	1	0802256	LEFT SUPPORT CHANNEL
27	1	0802257	RIGHT SUPPORT CHANNEL
28	1	0802260	TOP CHANNEL

Section VI - PARTS (cont'd)

BOOM ASSEMBLY

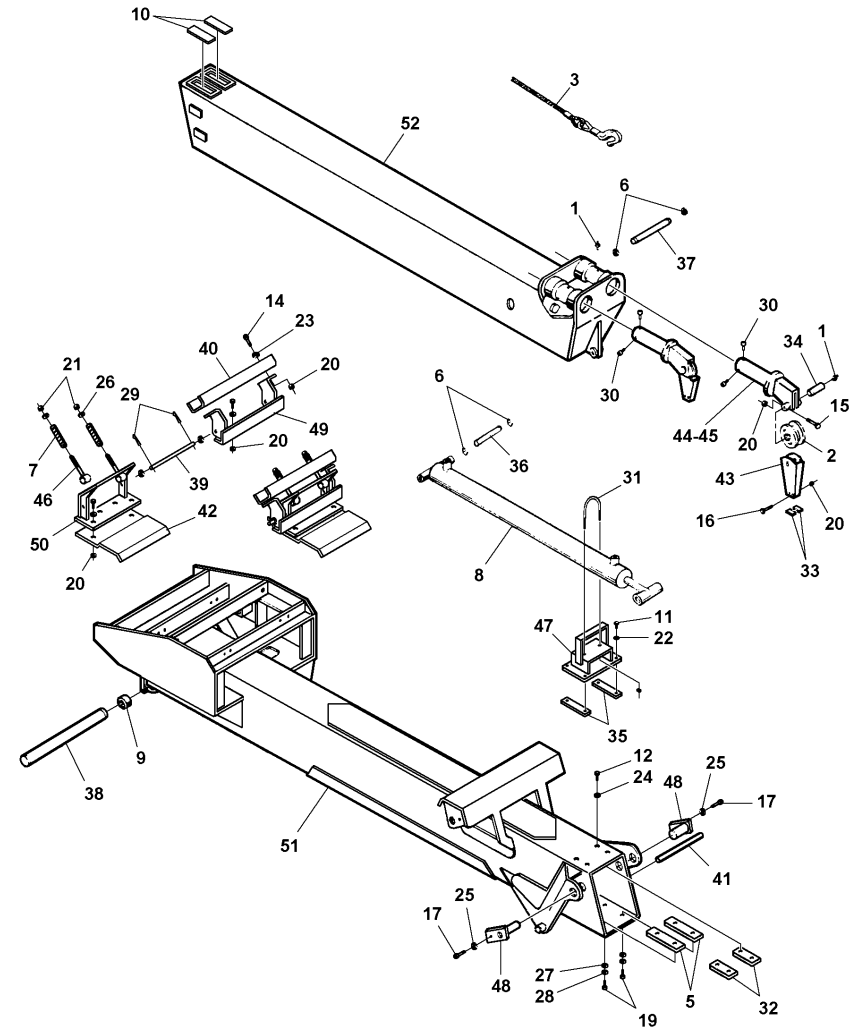

Section VI - PARTS (cont'd)

BOOM ASSEMBLY

REF. NO.	NO. REQ	PART NUMBER	DESCRIPTION
1	6	0300113	GREASE FITTING
2	2	0300626	SHEAVE, 8"
3	2	0301224	WIRE ROPE, 6 X 37 IWRC, 1/2" X 175 FT.
4	2	0301895	GREASE FITTING, STR 1/8"
5	2	0301923	SLIDE PAD, BOOM BOTTOM
6	4	0301959	SNAP RING, 1-1/2" INTERNAL
7	4	0302378	COMPRESSION SPRING
8	REF.	0302614	EXTEND CYLINDER
9	2	0302619	BUSHING, 2-1/4" OD X 2" ID X 1-1/2"
10	2	0302628	SLIDE PAD, INNER BOOM
11	4	0400066	SCREW, 1/4"-20 X 3/4" HEX HD CAP
12	4	0400121	SCREW, 3/8"-16 X 3/4" HEX HD CAP
13	4	0400122	SCREW, 3/8"-16 X 1-1/4" HEX HD CAP
14	18	0400132	SCREW, 3/8"-16 X 1-1/2" HEX HD CAP
15	2	0400133	SCREW, 3/8"-16 X 3" HEX HD CAP
16	4	0400150	SCREW, 3/8"-16 X 2-1/2" HEX HD CAP
17	2	0400176	SCREW, 1/2"-13 X 1" HEX HD CAP
18	1	0400220	SCREW, 1/2"-13 X 5-1/2" HEX HD CAP
19	4	0400248	SCREW, 5/8"-11 X 1" HEX HD CAP
20	24	0400392	NUT, 3/8"-16 HEX NYLOK
21	4	0400408	NUT, 1/2"-13 HEX NYLOK
22	4	0400451	WASHER, 1/4" FLAT
23	16	0400480	WASHER, 3/8" FLAT
24	4	0400482	LOCKWASHER, 3/8" HELICAL
25	2	0400491	LOCKWASHER, 1/2" HELICAL
26	8	0400492	WASHER, 1/2" FLAT

REF. NO.	NO. REQ	PART NUMBER	DESCRIPTION
27	4	0400506	WASHER, 5/8" FLAT
28	4	0400508	LOCKWASHER, 5/8" HELICAL
29	4	0400543	COTTER PIN, 1/8" X 3/4"
30	6	0400554	ROLL PIN, 3/8" X 1"
31	1	0400581	PIPE U-BOLT, 3/8"-18 X 3"
32	2	0700778	TOP SPACER, OUTER BOOM
33	4	0700801	BOTTOM CABLE GUIDE
34	2	0700888	SHAFT, SHEAVE
35	2	0703442	SKID, FAIRLEAD ASSEMBLY
36	1	0707343	EXTEND CYLINDER PIN, BASE
37	1	0707344	EXTEND CYLINDER PIN, ROD
38	1	0707342	PIVOT PIN, BOOM
39	2	0709361	PIVOT ROD
40	2	0709362	SPRING CHANNEL
41	1	0710143	PIN, TILT CYLINDER BASE END
42	2	0708645	PLATE, FLAPPER
43	2	0800286	CABLE GUIDE
44	1	0800509	SWIVEL WELDMENT, LEFT
45	1	0800510	SWIVEL WELDMENT, RIGHT
46	4	0802218	SPRING PIN
47	1	0802246	CYLINDER SUPPORT
48	2	0802365	PIN, TOWER PIVOT
49	2	0802775	TENSIONER MOUNTING BRACKET
50	2	0802774	TENSIONER BRACKET
51	1	0802849	OUTER BOOM WELDMENT
52	1	0802931	INNER BOOM WELDMENT

Section VI - PARTS (cont'd)

UNDERLIFT & TOWER ASSEMBLY

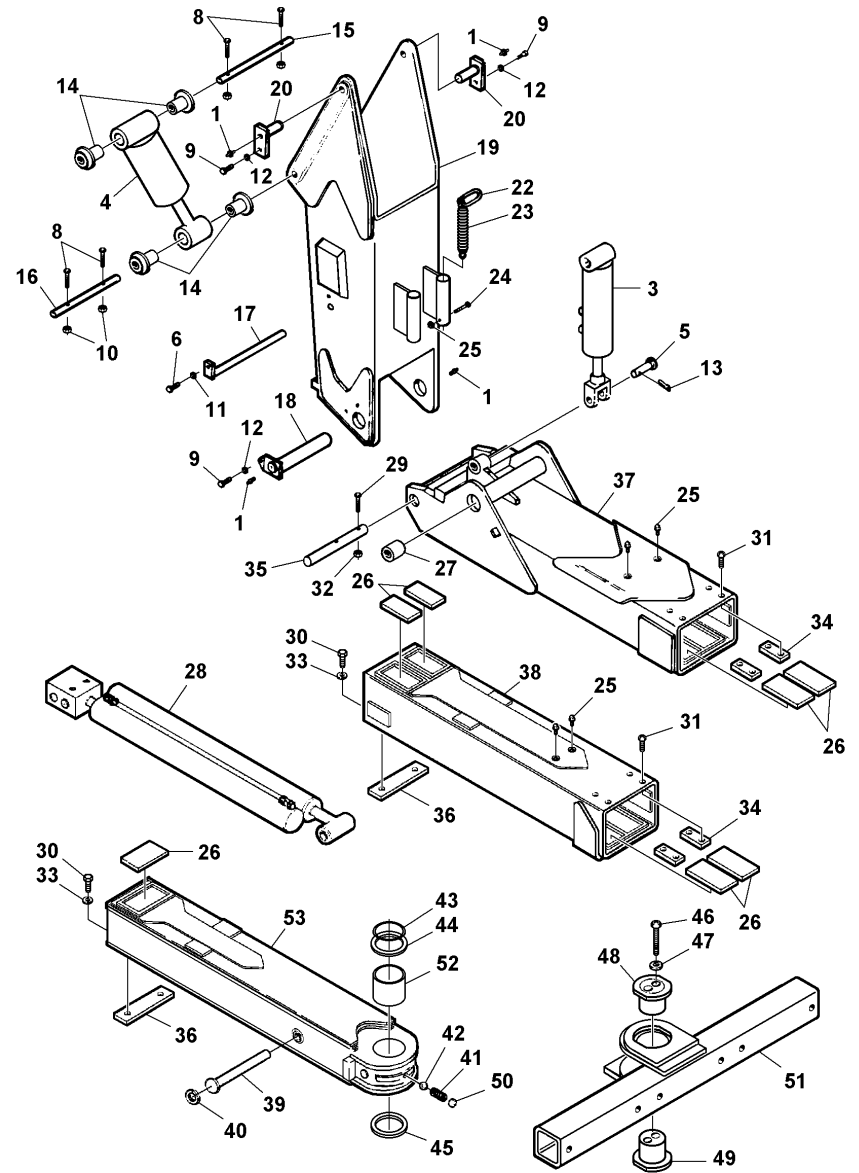

Section VI - PARTS (cont'd)

UNDERLIFT & TOWER ASSEMBLY

REF. NO.	NO. REQ'D	PART NUMBER	DESCRIPTION
1	6	0300113	GREASE FITTING
2	2	0301895	GREASE FITTING, 1/8" STR
3	REF.	0301765	FOLD CYLINDER
4	REF.	0302791	TILT CYLINDER
5	1	0304246	PIN, FOLD CYLINDER CLEVIS
6	1	0400121	SCREW, 3/8"-16 X 3/4" HEX HD CAP
7	1	0400122	SCREW, 3/8"-16 X 1-1/4" HEX HD CAP
8	4	0400167	SCREW, 3/8"-16 X 3-3/4" HEX HD CAP
9	3	0400176	SCREW, 1/2"-13 X 1" HEX HD CAP
10	7	0400392	NUT, 3/8"-16 NYLOK HEX
11	1	0400482	LOCKWASHER, 3/8" HELICAL
12	3	0400491	LOCKWASHER, 1/2" HELICAL
13	1	0400548	COTTER PIN, 3/8" X 2"
14	4	0710140	BUSHING, TILT CYLINDER
15	1	0710143	PIN, TILT CYLINDER BASE
16	1	0710144	PIN, TILT CYLINDER ROD END
17	1	0802220	FOLD CYLINDER PIN WELDMENT
18	1	0802237	UNDERLIFT PIVOT PIN
19	1	0802865	3224 TOWER WELDMENT
20	2	0802935	TOWER PIVOT PIN WELDMENT
--	--	0901716	WINCH CABLE STOW KIT
21	2	0301691	OBLONG MASTER LINK
22	2	0302273	SPRING, WINCH CABLE TIE-BACK
23	2	0400205	SCREW, 1/2"-13 X 3" HEX HD CAP
24	2	0400408	NUT, 1/2"-13 NYLOK HEX
--	--	0903059	HORIZONTAL BOOM ASSEMBLY
25	6	0300113	GREASE FITTING, 1/8" STR
26	7	0302561	SLIDE PAD
27	2	0302619	SPRING BUSHING

REF. NO.	NO. REQ'D	PART NUMBER	DESCRIPTION
--	--	0903752	HORIZONTAL BOOM ASSEMBLY (cont'd)
28	1	0303331	EXTEND CYLINDER
29	1	0400107	SCREW, 5/16"-18 X 2-1/2" HEX HD CAP
30	4	0400151	SCREW, 3/8"-24 X 3/4" HEX HD CAP
31	8	0400228	SCREW, 3/8"-24 X 5/8" BUTTON HD SKT
32	1	0400382	NUT, 5/16"-18 NYLOK HEX
33	4	0400481	LOCKWASHER, 3/8" EXTERNAL TOOTH
34	4	0707034	STOP PLATE
35	1	0707271	EXTEND CYLINDER PIN, BASE END
36	2	0707452	SPACER PAD
37	1	0803231	OUTER BOOM WELDMENT
38	1	0803232	2ND STAGE BOOM WELDMENT
39	1	HD86	EXTEND CYLINDER PIN WELDMENT
40	1	HD89	RETAINING RING, 1-5/16"
--	--	0903175	CROSSBAR ASSEMBLY
41	1	0301197	COMPRESSION SPRING, CROSSBAR
42	1	0301398	DETENT BALL, 1-3/16"
43	1	0303087	O-RING, PIVOT PIN
44	2	0303105	THRUST WASHER, 1/8"
45	2	0303106	THRUST WASHER, 1/16"
46	2	0400354	SCREW, 5/8"-11 X 3-1/2" SKT HD CAP
47	2	0400508	LOCKWASHER, 5/8" HELICAL
48	1	0710054	PIVOT PIN, TOP HALF
49	1	0710055	PIVOT PIN, BOTTOM HALF
50	1	0710195	SPACER, DETENT SPRING
51	1	0802919	CROSSBAR WELDMENT
--	--	0903751	INNER BOOM ASSEMBLY
52	1	0302625	BUSHING, PIVOT PIN
53	1	0803320	3RD STAGE BOOM WELDMENT

Section VI - PARTS (cont'd)

UNDERLIFT HYDRAULICS

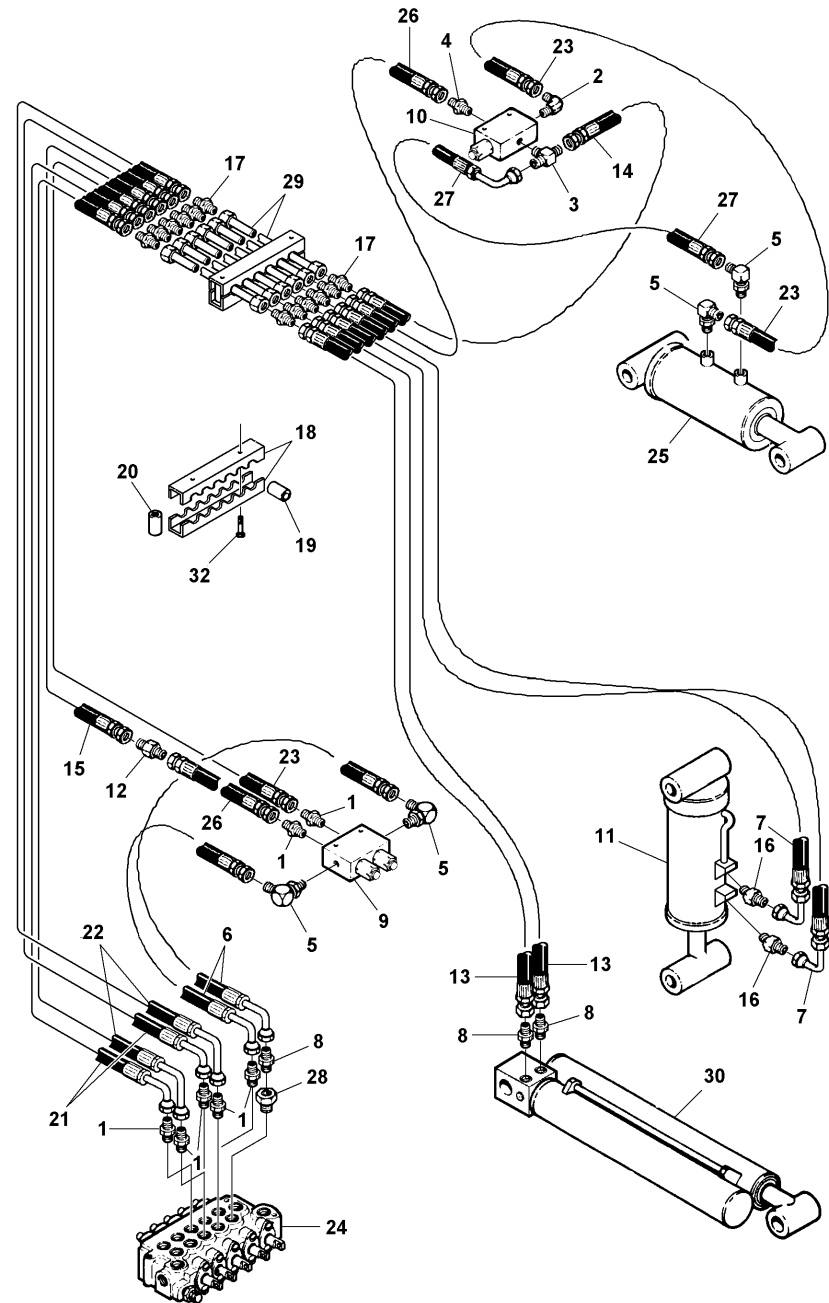

Section VI - PARTS (cont'd)

UNDERLIFT HYDRAULICS

REF. NO.	NO. REQ	PART NUMBER	DESCRIPTION
1	7	0300044	CONNECTOR, 6MJ-8MB
2	1	0300142	ELBOW, 6MJ-4MP90
3	1	0300206	BRANCH TEE, 6MJ-6MJ-4MP
4	1	0301424	CONNECTOR, 6MJ-4MP
5	4	0301470	ELBOW, 6MJ-8MP90
6	2	0301473	HOSE ASSEMBLY, 18"
7	2	0301485	HOSE ASSEMBLY, 81"
8	3	0301522	CONNECTOR, 6MJ-6MB
9	1	0301730	DOUBLE HOLDING VALVE
10	1	0301731	HOLDING VALVE
11	1	0301765	FOLD CYLINDER
12	1	0301837	INLINE ORIFICE
13	2	0301880	HOSE ASSEMBLY, 107"
14	1	0302035	HOSE ASSEMBLY, 18"
15	1	0302036	HOSE ASSEMBLY, 26"
16	2	0302509	ELBOW, 6MJ-6MB45
17	12	0302514	ADAPTER, 8MJ-6MJ
18	4	0302548	CLAMPING UNIT
19	12	0302549	SPLIT BUSHING, 1/2"
20	4	0302551	STACKING NUT, SKT HD
21	2	0302581	HOSE ASSEMBLY, 36"
22	2	0302582	HOSE ASSEMBLY, 36"
23	2	0302596	HOSE ASSEMBLY, 34"
24	REF.	REF.	CONTROL VALVE
25	1	0302791	TILT CYLINDER
26	2	0302805	HOSE ASSEMBLY, 10"
27	1	0302815	HOSE ASSEMBLY, 32"
28	1	0303017	CONNECTOR, 8MB-6FB
29	6	0303108	TUBE ASSEMBLY
30	1	0303331	EXTEND CYLINDER
31	2	0400064	SCREW, 1/4"-20 X 2" RD HD SLOTTED
32	4	0400118	SCREW, 5/16"-18 X 3/4" HEX HD CAP
33	2	0400366	NUT, 1/4"-20 HEX
34	2	0400451	WASHER, 1/4" FLAT
35	2	0400452	LOCKWASHER, 1/4" HELICAL

Section VI - PARTS (cont'd)

BOOM ELEVATION HYDRAULICS

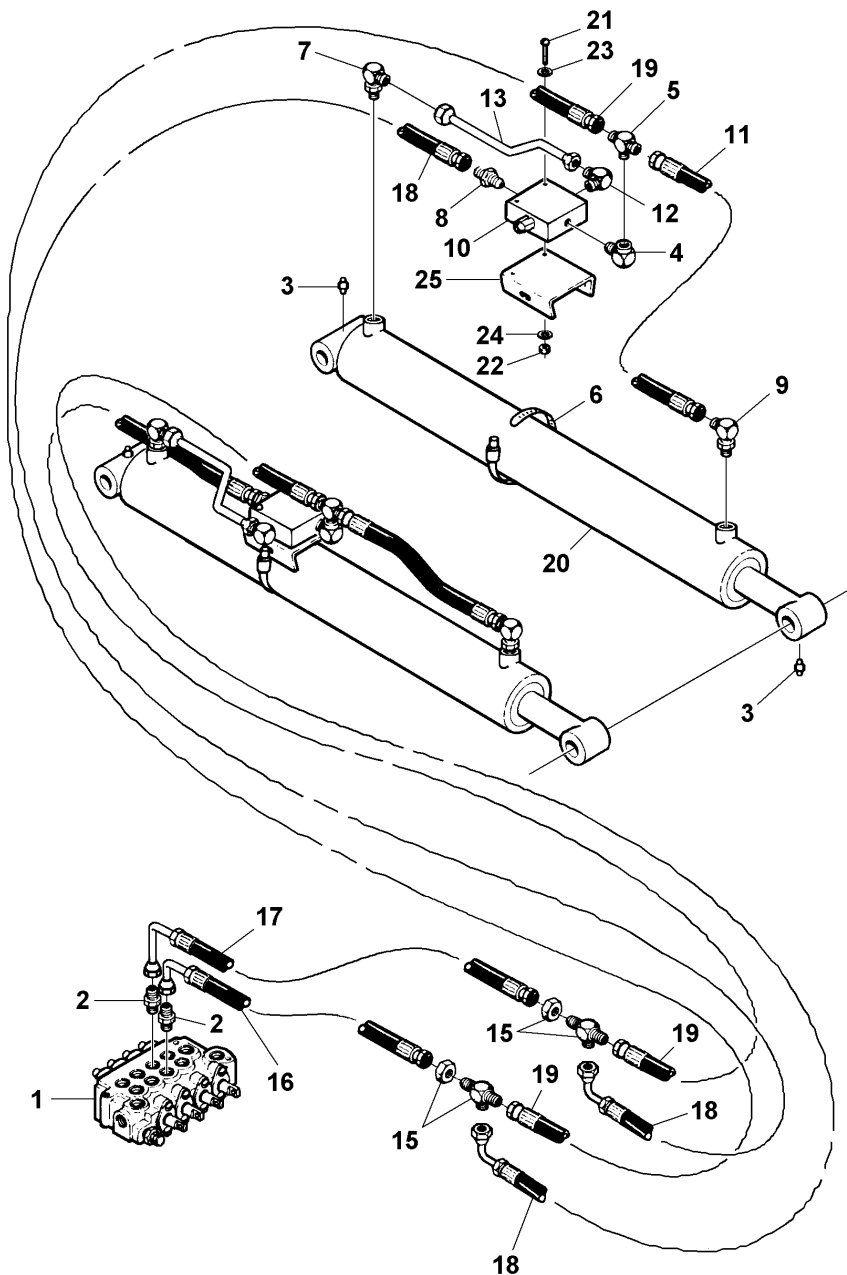

Section VI - PARTS (cont'd)

BOOM ELEVATION HYDRAULICS

REF. NO.	NO. REQ'D	PART NUMBER	DESCRIPTION
1	REF.	REF.	CONTROL VALVE
2	2	0300044	CONNECTOR, 6MJ-8MB
3	4	0300113	GREASE FITTING
4	2	0300147	ELBOW, STREET 4MP-4FP90
5	2	0300206	BRANCH TEE, 6MJ-6MJ-4MP
6	2	0300710	CLAMP, CHECK VALVE RETAINING, 6-1/2"
7	2	0301388	ELBOW, 8MJ-8MB90
8	2	0301425	CONNECTOR, 6MJ-6MP
9	2	0301470	ELBOW, 6MJ-8MB90
10	2	0301731	HOLDING VALVE
11	2	0302035	HOSE ASSEMBLY, 18"
12	2	0302051	ELBOW, 8MJ-6MP90
13	2	0302568	TUBING, HYDRAULIC
14	4	0302569	WIRE TIE, 29-3/4"
15	2	0302575	BULKHEAD RUN TEE W/NUT
16	1	0302581	HOSE ASSEMBLY, 36"
17	1	0302582	HOSE ASSEMBLY, 36"
18	2	0302604	HOSE ASSEMBLY, 44"
19	2	0302632	HOSE ASSEMBLY, 40"
20	2	0303091	CYLINDER, BOOM LIFT
21	4	0400064	SCREW, 1/4"-20 X 2-1/4" RD HD SLOTTED
22	4	0400366	NUT, 1/4"-20 HEX
23	4	0400451	WASHER, 1/4" FLAT
24	4	0400452	LOCKWASHER, 1/4" HELICAL
25	2	0703001	BRACKET, CHECK VALVE MOUNTING

Section VI - PARTS (cont'd)

BOOM EXTENSION HYDRAULICS

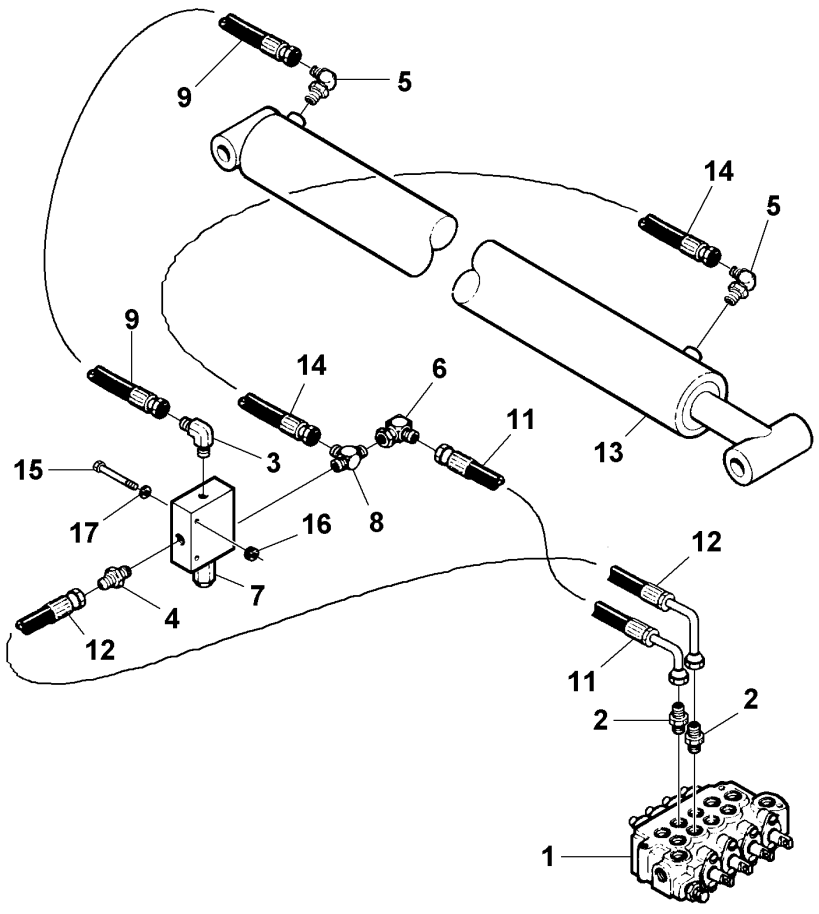

Section VI - PARTS (cont'd)

BOOM EXTENSION HYDRAULICS

REF. NO.	NO. REQ'D	PART NUMBER	DESCRIPTION
1	REF.	REF.	CONTROL VALVE
2	2	0300044	CONNECTOR, 6MJ-8MB
3	1	0300209	ELBOW, 6MJ-6MP90
4	1	0301425	CONNECTOR, 6MJ-6MP
5	2	0301620	ELBOW, 6MJ-6MB90
6	1	0301696	ELBOW, 6MJ-6FJX90
7	1	0301731	HOLDING VALVE
8	1	0301782	MALE RUN TEE, 6MJ-4MP-6MJ
9	1	0302000	HOSE ASSEMBLY, 24"
10	5	0302062	WIRE TIE, 21" (NOT SHOWN)
11	1	0302581	HOSE ASSEMBLY, 36"
12	1	0302605	HOSE ASSEMBLY, 44"
13	1	0302614	EXTEND CYLINDER
14	1	0302635	HOSE ASSEMBLY, 131"
15	2	0400122	SCREW, 3/8"-16 X 1-1/4" HEX HD CAP
16	2	0400392	NUT, 3/8"-16 NYLOK HEX
17	2	0400480	WASHER, 3/8" FLAT

Section VI - PARTS (cont'd)

PUMP, VALVE & FILTER HYDRAULICS

Section VI - PARTS (cont'd)

PUMP, VALVE & FILTER HYDRAULICS

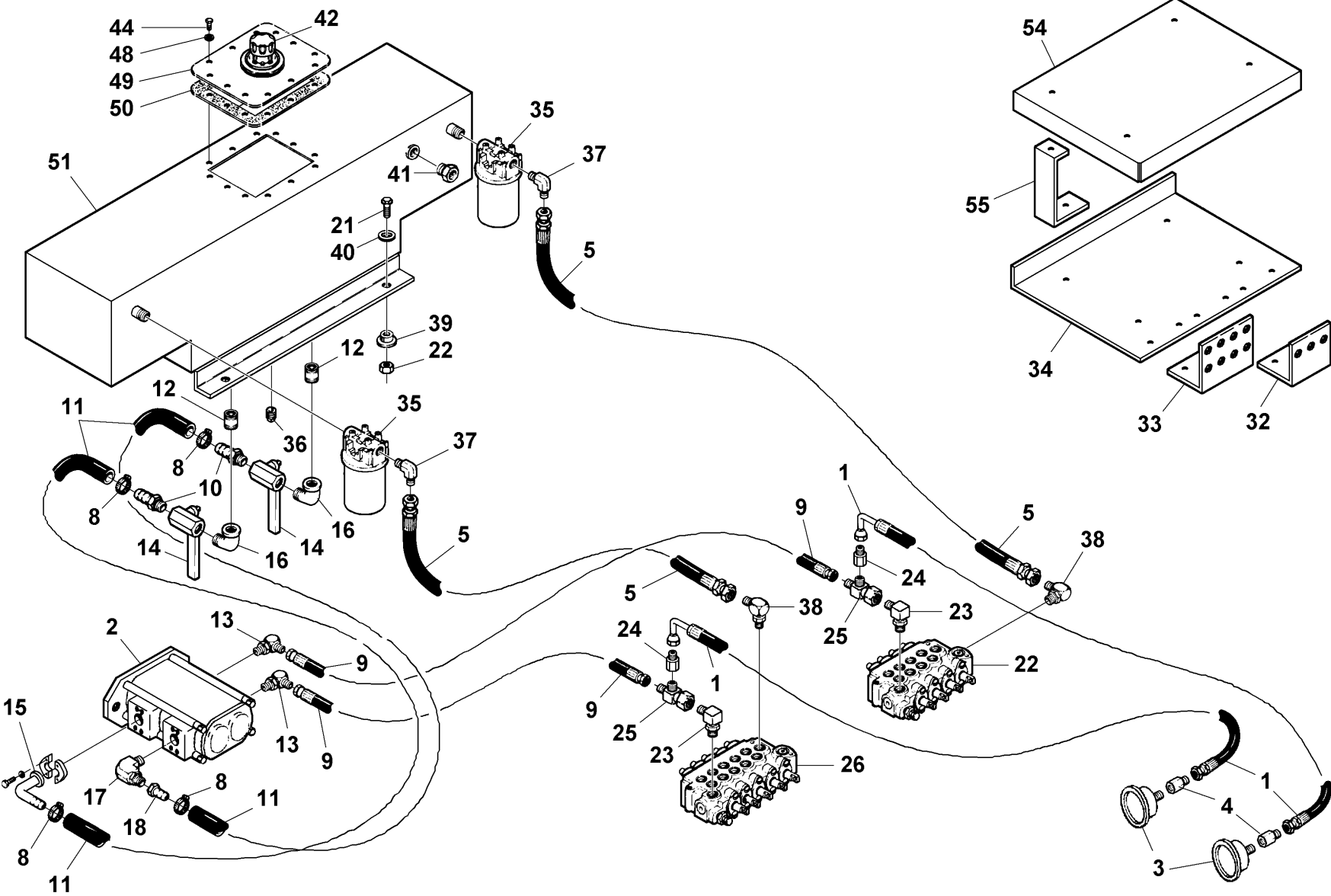

Section VI - PARTS (cont'd)

PUMP, VALVE & FILTER HYDRAULICS

REF. NO.	NO. REQ'D	PART NUMBER	DESCRIPTION
1	2	0301485	HOSE ASSEMBLY, 81"
2	1	0301507	PUMP, OPPOSITE ENGINE
3	2	0302205	GAUGE, FLUSH MOUNT 6000 PSI
4	2	0302577	CONNECTOR, 6MJ-4FP
5	2	0303435	HOSE ASSEMBLY, 58"
6	6	0400021	SCREW, # 8-32 X 1/2" RD HD PHIL MACH
7	6	0400351	HEX NUT & STAR WASHER, # 8-32
--	--	0903307	PUMP KIT
8	2	0300364	CLAMP, HOSE, 1" - 2-1/4"
9	2	0300660	HOSE ASSEMBLY, 120"
10	2	0300666	BARB, 24C4-24MP
11	20 FT.	0300671	SUCTION HOSE, 1-1/2"
12	2	0300891	PIPE NIPPLE, 1-1/2" X 3"
13	2	0301547	ELBOW, 8MJ-12MB90
14	2	0302088	BALL VALVE, BRONZE
15	1	0302242	FLANGE FITTING, 24FL-24HOSE90
16	2	0302983	STREET ELBOW, 45°, 1-1/2"
17	1	0303032	ELBOW, 24MJ-20MB90
18	1	0303033	HOSE BARB, 24C4-24FJX
19	6	0303290	CLAMP, 2-1/2" INSULATED
20	2	0400188	SCREW, 1/2"-13 X 2" HEX HD CAP
21	2	0400408	NUT, 1/2"-13 NYLOK HEX
--	--	0903535	VALVE PAN ASSEMBLY
22	REF.	REF.	CONTROL VALVE
23	2	0300052	ELBOW, 8MJ-10MB90
24	2	0301995	STRAIGHT ADAPTER, 8FJ-6MJ
25	2	0302052	RUN TEE, 8MJ-8FJX-8MJ
26	REF.	REF.	CONTROL VALVE
27	6	0400135	SCREW, 3/8"-16 X 4-1/2" HEX HD CAP
28	4	0400157	SCREW, 3/8"-16 X 1-3/4" HEX HD CAP

REF. NO.	NO. REQ'D	PART NUMBER	DESCRIPTION
29	10	0400392	NUT, 3/8"-16 NYLOK HEX
30	4	0400480	WASHER, 3/8" FLAT
31	6	0704045	SPACER, CONTROL VALVE
32	1	0711250	PLATE, CONTROL BULKHEAD
33	2	0711251	PLATE, CONTROL BULKHEAD
34	1	0711561	PLATE, VALVE MOUNTING
--	--	0902353	TANK KIT
35	2	0300136	RETURN LINE FILTER ASSEMBLY
36	1	0300446	PIPE PLUG, 3/4" NPT MALE
37	2	0300615	ELL, 12MJ-12MP90
38	2	0301545	ELBOW, 12MJ-12MB90
39	4	0302227	CENTER BONDED MOUNT
40	4	0302228	SPECIAL WASHER
41	1	0302570	SIGHT GAUGE
42	1	0305006	FILLER CAP
43	6	0400036	SCREW, # 10-32 X 1" RD HD MACH
44	12	0400122	SCREW, 3/8"-16 X 1-1/4" HEX HD CAP
45	4	0400146	SCREW, 3/8"-16 X 2-1/4" HEX HD CAP
46	6	0400357	NUT, # 10-32 NYLOK HEX
47	4	0400392	NUT, 3/8"-16 NYLOK HEX
48	12	0400482	LOCKWASHER, 3/8" HELICAL
49	1	0705910	COVER PLATE
50	1	0706114	GASKET, CLEANOUT & FILLER COVER
51	1	0803163	RESERVOIR WELDMENT
--	--	0903696	COVER KIT
52	4	0400121	SCREW, 3/8"-16 X 3/4" HEX HD CAP
53	4	0400392	NUT, 3/8"-16 NYLOK HEX
54	1	0711322	COVER, VALVE
55	4	0711575	SUPPORT, COVER

Section VI - PARTS (cont'd)

WINCH HYDRAULICS & AIR FREE SPOOL

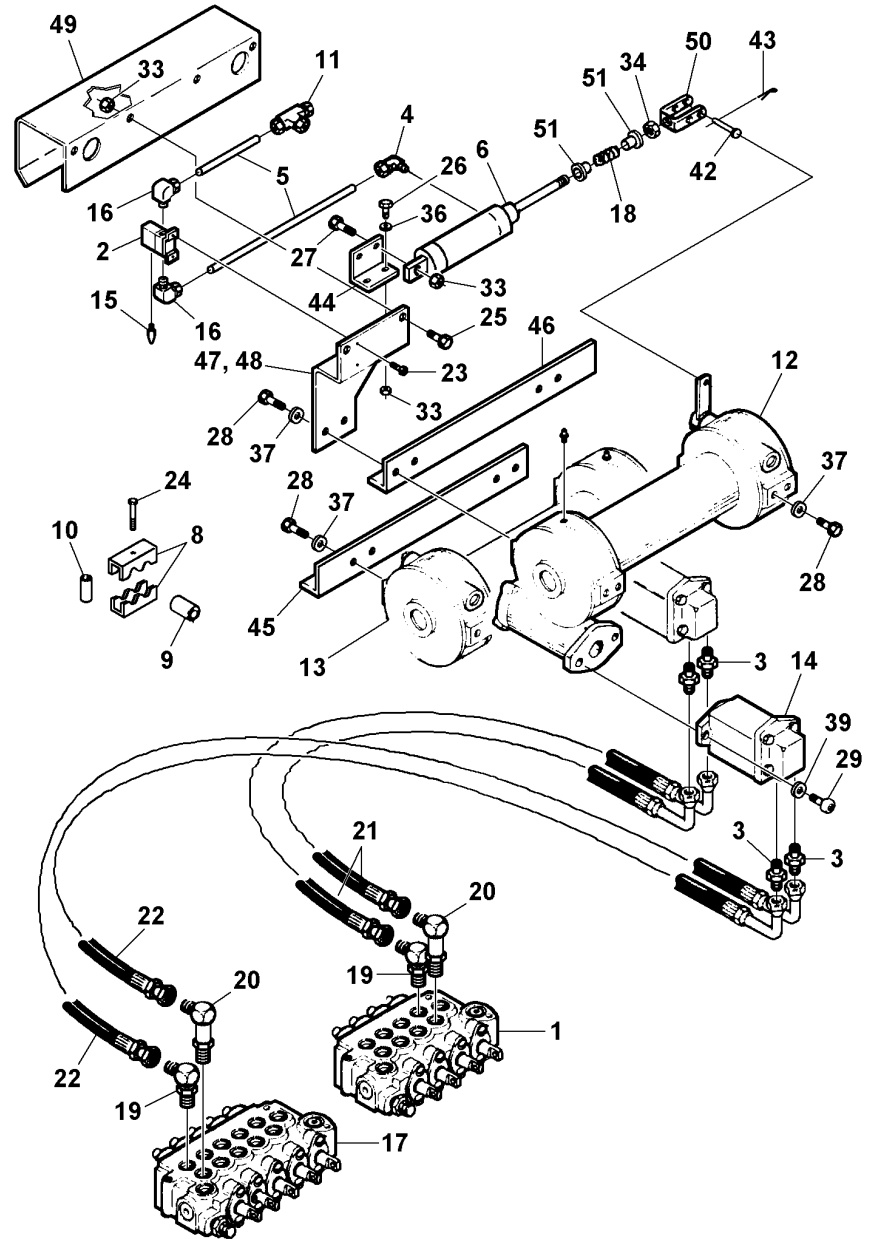

Section VI - PARTS (cont'd)

WINCH HYDRAULICS & AIR FREE SPOOL

REF. NO.	NO. REQ	PART NUMBER	DESCRIPTION
1	REF.	0300011	CONTROL VALVE
2	2	0300324	SOLENOID VALVE, AIR CONTROL
3	4	0301376	CONNECTOR, 10MJ-16MB
4	2	0301574	ELBOW, 4TB-4MP90
5	18 FT.	0301577	AIR HOSE, 1/4" O.D.
6	2	0302055	AIR CYLINDER
7	7 FT.	0302431	CONVOLUTED LOOM, 3/8"(NOT SHOWN)
8	4	0302546	CLAMPING UNIT
9	4	0302550	SPLIT BUSHING, 3/4"
10	2	0302551	STACKING NUT, SKT HD
11	1	0302607	TEE UNION, 4TB-4TB-4TB
12	1	0302617	WINCH, H-600 LEFT
13	1	0302618	WINCH, H-600 RIGHT
14	2	0302627	HYDRAULIC MOTOR
15	2	0302677	BREATHER VENT, 1/8" MP
16	4	0302678	ELBOW, 4TB-2MP90
17	REF.	0302782	CONTROL VALVE
18	2	0302795	SPRING, COMPRESSION
19	2	0302827	CONNECTOR, 10MJ-10MB
20	2	0302828	CONNECTOR, 10MJ-10MBL
21	2	0303131	HOSE ASSEMBLY, 80"
22	2	0303391	HOSE ASSEMBLY, 96"
23	4	0400034	SCREW, # 10-32 X 1/2" RD HD PHIL
24	2	0400118	SCREW, 5/16"-18 X 3/4" HEX HD CAP
25	4	0400121	SCREW, 3/8"-16 X 3/4" HEX HD CAP
26	4	0400122	SCREW, 3/8"-16 X 1-1/4" HEX HD CAP

REF. NO.	NO. REQ	PART NUMBER	DESCRIPTION
27	2	0400132	SCREW, 3/8"-16 X 1-1/2" HEX HD CAP
28	16	0400234	SCREW, 7/16"-14 X 1-1/4" HEX HD CAP
29	4	0400238	SCREW, 1/2"-13 X 1-1/2" SKT HD CAP
30	8	0400260	SCREW, 5/8"-11 X 2" HEX HD CAP
31	4	0400356	NUT, # 10-32 HEX
32	10	0400367	NUT, 1/4"-20 HEX NYLOK
33	8	0400392	NUT, 3/8"-16 HEX NYLOK
34	2	0400412	NUT, 1/2"-20 HEX JAM
35	8	0400421	NUT, 5/8"-11 HEX NYLOK
36	8	0400480	WASHER, 3/8" FLAT
37	16	0400487	LOCKWASHER, 7/16" HELICAL
38	2	0400488	WASHER, 7/16" FLAT
39	8	0400491	LOCKWASHER, 1/2" HELICAL
40	16	0400504	WASHER, 5/8" SAE
41	4	0400520	LOCKWASHER, # 10 HELICAL
42	2	0400530	CLEVIS PIN, 5/16" X 1-1/4"
43	2	0400543	COTTER PIN, 1/8" X 3/4"
44	2	0702382	MOUNTING ANGLE
45	1	0707337	WINCH MOUNTING ANGLE, FRONT
46	1	0707338	WINCH MOUNTING ANGLE, REAR
47	1	0707416	BRACKET, FREESPOOL, LEFT
48	1	0707417	BRACKET, FREESPOOL, RIGHT
49	2	0707418	FREESPOOL COVER
50	2	0800772	ADJUSTMENT YOKE
51	4	RR809	BUSHING, CONTROL HANDLE

Section VI - PARTS (cont'd)

LEFT CONTROL ASSEMBLY

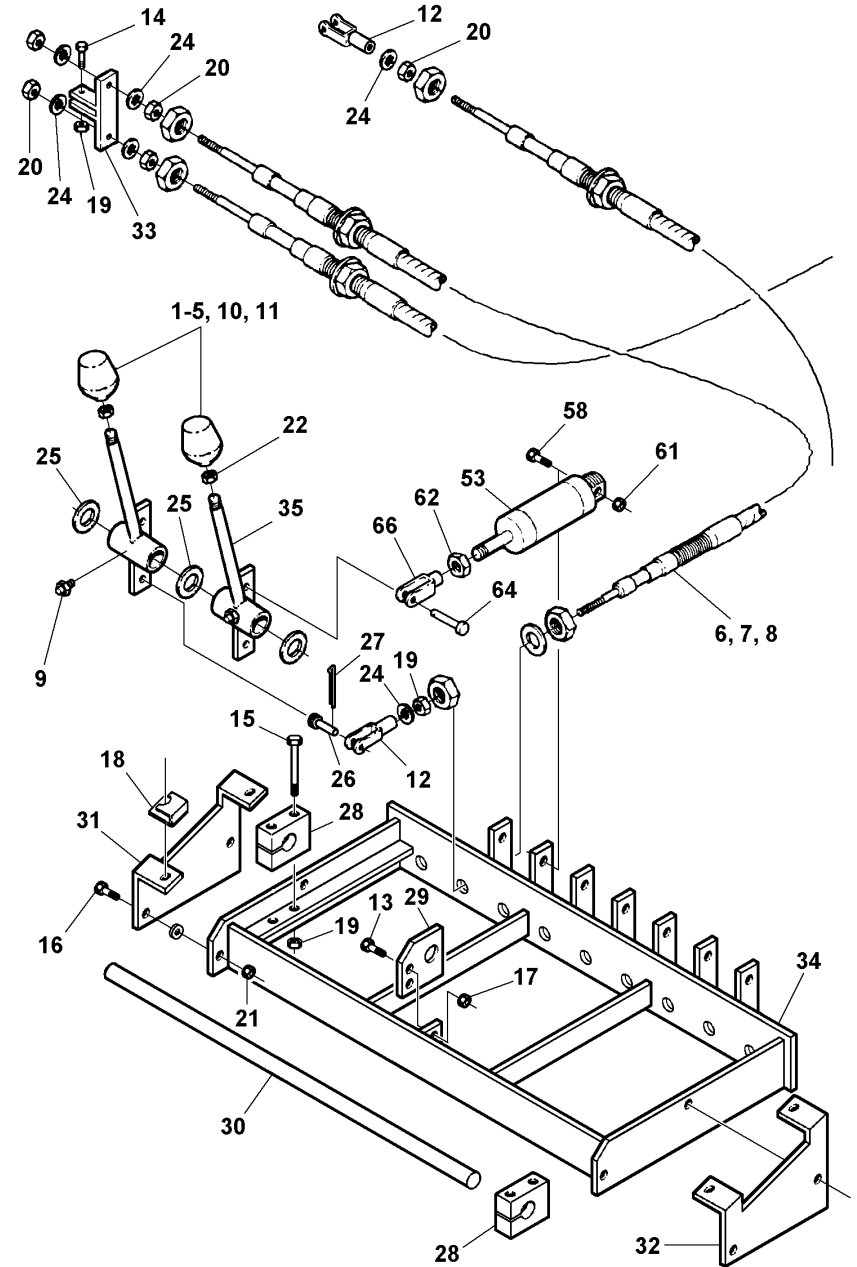

Section VI - PARTS (cont'd)

LEFT CONTROL ASSEMBLY

REF. NO.	NO. REQ	PART NUMBER	DESCRIPTION
1	1	0300341	CONTROL KNOB, W/L (UP/DOWN)
2	2	0300834	CONTROL KNOB, (IN/OUT)
3	1	0300835	CONTROL KNOB, BOOM (UP/DOWN)
4	2	0300836	CONTROL KNOB, JACK (UP/DOWN)
5	1	0300837	CONTROL KNOB, BOOM (IN/OUT)
6	4	0302453	CONTROL CABLE, 92"
7	1	0302454	CONTROL CABLE, 67"
8	4	0302455	CONTROL CABLE, 79"
9	9	0302726	GREASE FITTING, 1/4"-28 X 45°
10	1	0302856	CONTROL KNOB, TILT (UP/DOWN)
11	1	0302917	CONTROL KNOB, W/L EXTEND (IN/OUT)
12	12	0303008	ADJUSTABLE CLEVIS
13	2	0400066	SCREW, 1/4"-20 X 3/4" HEX HD CAP
14	9	0400103	SCREW, 5/16"-18 X 1-1/4" HEX HD CAP
15	4	0400107	SCREW, 5/16"-18 X 2-1/2" HEX HD CAP
16	4	0400122	SCREW, 3/8"-16 X 1-1/4" HEX HD CAP
17	2	0400367	NUT, 1/4"-20 HEX NYLOK
18	4	0400379	NUT, 5/16"-18 "J" TINNEMAN
19	9	0400382	NUT, 5/16"-18 HEX NYLOK
20	36	0400383	NUT, 5/16"-24 HEX
21	10	0400392	NUT, 3/8"-16 HEX NYLOK
22	9	0400393	NUT, 3/8"-16 HEX JAM
23	4	0400451	WASHER, 1/4" FLAT
24	24	0400466	WASHER, 5/16" INTERNAL TOOTH
25	10	0400512	WASHER, 3/4" FLAT (SPECIAL)
26	9	0400532	CLEVIS PIN, 5/16" X 1"
27	9	0400541	COTTER PIN, 1/16" X 3/4"
28	2	0711235	CLAMP, SHAFT CONTROL BOX
29	1	0711245	PLATE, SHAFT SUPPORT
30	1	0711246	PIN, CONTROL BOX
31	1	0711284	SUPPORT, CONTROL (LEFT)
32	1	0711285	SUPPORT, CONTROL (RIGHT)
33	6	0801054	CONTROL CABLE CONNECTOR
34	1	0803182	CONTROL FRAME WELDMENT
35	9	0803294	CONTROL HANDLE WELDMENT

REMOTE CONTROL ASSEMBLY

REF. NO.	NO. REQ	PART NUMBER	DESCRIPTION
--	--	--	REMOTE CONTROL ASSEMBLY
36	10 / 16	0300166	WIRE CONNECTOR, SPADE
37	1	0301574	ELBOW, 4TB-4MP90
38	15 / 25	0301577	AIR HOSE, 1/4" O.D. (FT.)
39	2 / 4	0301610	CONNECTOR, 4TB-4MP
40	2 / 3	0301618	BRASS PLUG, 4MP
41	2	0302048	CABLE SEALING GRIP
42	2	0302340	HEX PIPE BUSHING
43	1	0302431	CONVOLUTED LOOM, 3/8" X 8"
44	35 / 65	0302434	CABLE TIE, 4" 18 LB.
45	1 / 2	0302677	BREATHER VENT, 2MP
46	16 / 28	0302678	ELBOW, 4TB-2MP
47	1	0302844	AIR SOLENOID VALVE (8)
--	1	0303479	AIR SOLENOID VALVE (14)
48	1	0303226	CIRCUIT BREAKER, HI-AMP WATERPROOF
49	1 / 2	0303235	TERMINAL BLOCK
50	1	0303250	POWER PAL, 15 POSITION
51	1	0303251	POWER PAL, 8 POSITION
52	8 / 20	0303322	ELECTRICAL CABLE, 16/10 SO (FT.)
53	4 / 7	0303335	AIR CYLINDER
54	1	0303363	AIR FILTER/REGULATOR
55	1	0303364	AIR LUBRICATOR
56	1	0303365	MOUNTING BRACKET
57	2 / 4	0400025	SCREW, # 8-32 X 3/4" RD HD SLOTTED
58	4 / 7	0400057	SCREW, 1/4"-20 X 1-1/4" HEX HD CAP
59	2 / 4	0400078	SCREW, 1/4"-20 X 2" HEX HD CAP
60	2 / 4	0400351	HEX NUT & STAR WASHER, # 8-32
61	6 / 11	0400367	NUT, 1/4"-20 HEX NYLOK
62	4 / 7	0400401	NUT, 7/16"-20 HEX JAM
63	2 / 4	0400451	WASHER, 1/4" FLAT
64	4 / 7	0400527	CLEVIS PIN, 5/16" X 5/8" COTTERLESS
65	1	0711277	SUPPORT, SOLENOID VALVE (8)
--	1	0711836	SUPPORT, SOLENOID VALVE (14)
66	4 / 7	0803181	CLEVIS WELDMENT
67	1	HA0132	GAUGE, 0-160 PSI

Section VI - PARTS (cont'd)
RIGHT CONTROL ASSEMBLY

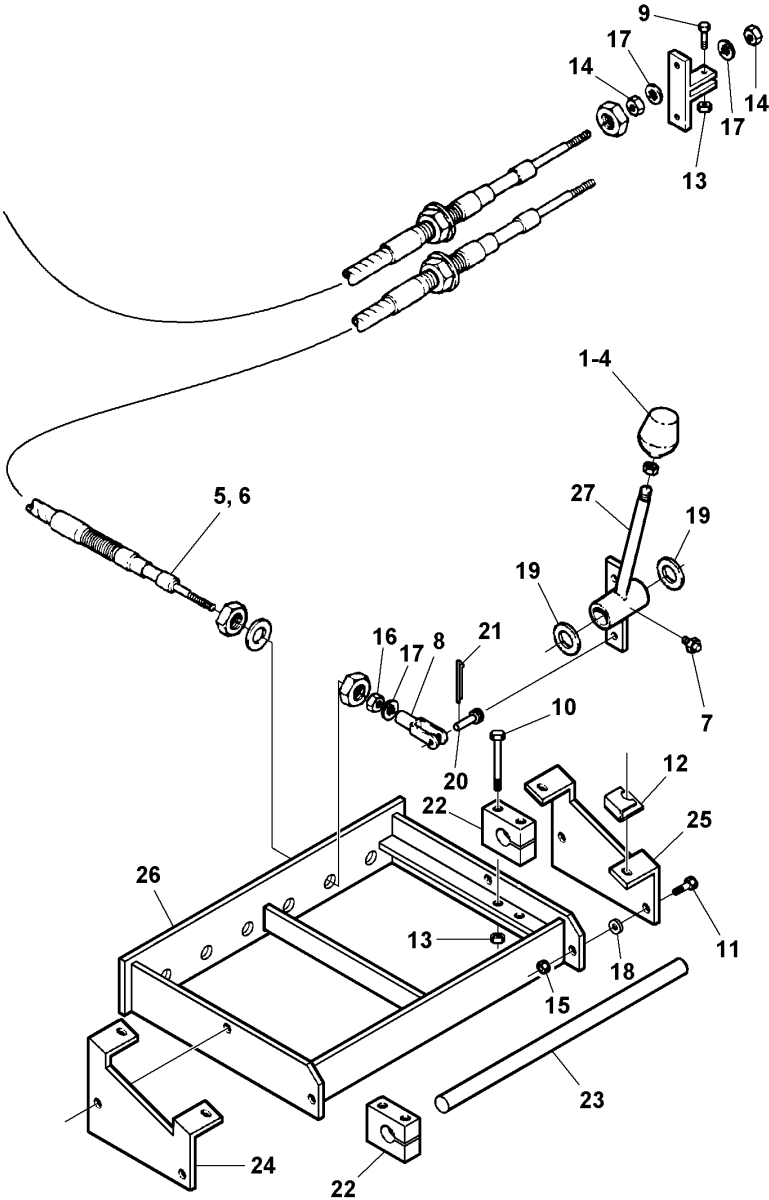

Section VI - PARTS (cont'd)

RIGHT CONTROL ASSEMBLY

REF. NO.	NO. REQ	PART NUMBER	DESCRIPTION
1	2	0300834	CONTROL KNOB, (IN/OUT)
2	1	0300835	CONTROL KNOB, BOOM (UP/DOWN)
3	2	0300836	CONTROL KNOB, JACK (UP/DOWN)
4	1	0300837	CONTROL KNOB, BOOM (IN/OUT)
5	3	0303453	CONTROL CABLE, 92"
6	3	0302455	CONTROL CABLE, 79"
7	6	0302726	GREASE FITTING, 1/4"-28 X 45°
8	6	0303008	ADJUSTABLE CLEVIS
9	6	0400103	SCREW, 5/16"-18 X 1-1/4" HEX HD CAP
10	4	0400107	SCREW, 5/16"-18 X 2-1/2" HEX HD CAP
11	4	0400122	SCREW, 3/8"-16 X 1-1/4" HEX HD CAP
12	4	0400379	NUT, 5/16"-18 "J" TINNERMAN
13	10	0400382	NUT, 5/16"-18 HEX NYLOK
14	18	0400383	NUT, 5/16"-24 HEX
15	4	0400392	NUT, 3/8"-16 HEX NYLOK
16	6	0400393	NUT, 3/8"-16 HEX JAM
17	18	0400466	WASHER, 5/16" INTERNAL TOOTH
18	4	0400480	WASHER, 3/8" FLAT
19	7	0400512	WASHER, 3/4" FLAT (SPECIAL)
20	6	0400532	CLEVIS PIN, 5/16" X 1"
21	6	0400541	COTTER PIN, 1/16" X 3/4"
22	2	0711235	CLAMP, SHAFT CONTROL BOX
23	1	0711247	PIN, CONTROL BOX
24	1	0711284	SUPPORT, CONTROL (LEFT)
25	1	0711285	SUPPORT, CONTROL (RIGHT)
26	1	0803183	CONTROL FRAME WELDMENT
27	6	0803294	CONTROL HANDLE WELDMENT

Section VI - PARTS (cont'd)

H-600SC WINCH ASSEMBLY

Section VI - PARTS (cont'd)
H-600SC WINCH ASSEMBLY

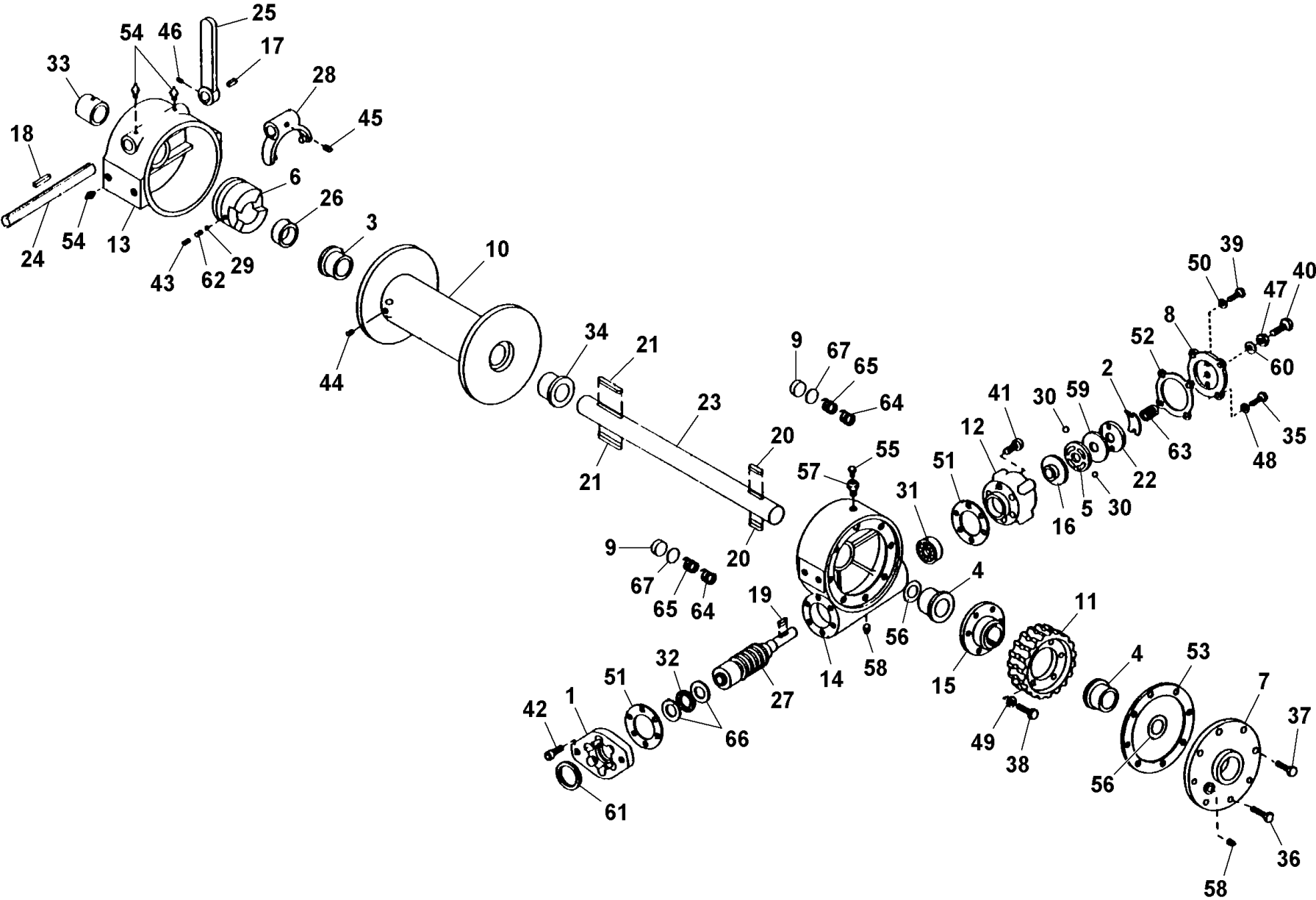

Section VI - PARTS (cont'd)

H-600SC WINCH ASSEMBLY

REF NO.	NO. REQ	PART NUMBER	DESCRIPTION
1	1	300062	ADAPTER
2	1	306036	SPRING, FLAT
3	1	308046	BUSHING
4	2	308048	BUSHING
5	1	314003	CAM PLATE
6	1	324163	CLUTCH, JAW
7	1	328046	COVER, GEAR HOUSING
8	1	328057	COVER, BRAKE
9	2	330010	SHOE, DRAG BRAKE
10	1	332140	DRUM
11	2	334050	GEAR, R.H.
12	1	338038	HOUSING, BRAKE
13	1	338040	HOUSING, CLUTCH
14	1	338270	HOUSING, GEAR
15	1	340014	HUB, GEAR
16	1	340024	HUB, BRAKE
17	1	342024	KEY
18	1	342032	KEY
19	1	342051	KEY
20	2	342120	KEY
21	2	450017	KEY, BARTH
22	1	352020	PLATE, RETAINER
23	1	357466	SHAFT, DRUM
24	1	356945	SHAFT, SHIFTER
25	1	358001	SHIFTER HANDLE
26	1	362007	SPACER, DRUM
27	1	368195	WORM, R.H.
28	1	370003	YOKE
29	1	400003	BALL, POPPET
30	1	400007	BALL
31	1	402044	BEARING, BALL
32	1	402107	BEARING, THRUST
33	1	412005	BUSHING
34	1	412006	BUSHING

REF NO.	NO. REQ	PART NUMBER	DESCRIPTION
35	4	414111	CAPSCREW, 5/16"-18 X 1" LG HEX HD
36	1	414140	CAPSCREW, 5/16"-18 X 3/4" LG HEX HD NYLOK
37	7	414141	CAPSCREW, 5/16"-18 X 1" LG HEX HD NYLOK
38	6	414283	CAPSCREW, 3/8"-16 X 1-1/4" LG HEX HD
39	2	414398	CAPSCREW, 3/8"-24 X 1" LG HEX HD NYLOK
40	1	414603	CAPSCREW, 1/2"-20 X 1-3/4" LG HX HD ALL-THRD
41	6	414865	CAPSCREW, 5/16"-18 X 1" LG HEX SOC HD
42	6	414887	CAPSCREW, 5/16"-18 X 1" LG BUTTON HD
43	1	414971	SCREW, POPPET 1/2"-20 HD LESS DR SLOT
44	1	416059	SETSCREW, 3/8"-16 X 1/2" LG HEX SOC HD
45	1	416109	SETSCREW, 5/16"-18 X 1/2" LG SQ HD
46	1	416112	SETSCREW, 5/16"-18 X 3/4" LG SQ HD
47	1	418067	NUT, 1/2"-20 HEX JAM
48	4	418163	LOCKWASHER, 5/16" MED SECT
49	6	418176	LOCKWASHER, 3/8" MED SECT
50	2	418184	WASHER, FLAT 3/8" ALUM.
51	2	442182	GASKET
52	1	442190	GASKET
53	1	442191	GASKET
54	3	456006	FITTING, LUBE
55	1	456008	FITTING, RELIEF
56	2	462003	QUAD, RING
57	1	468002	REDUCER
58	2	468011	PIPE PLUG
59	1	474004	PLATE
60	1	486076	THREAD SEAL
61	1	486079	SEAL, PILOT
62	1	494005	SPRING
63	1	494010	SPRING
64	2	494088	SPRING
65	2	494089	SPRING
66	2	518026	THRUST WASHER
67	2	530094	SPACER, BRAKE

Section VI - PARTS (cont'd)

REAR SPADE HYDRAULICS

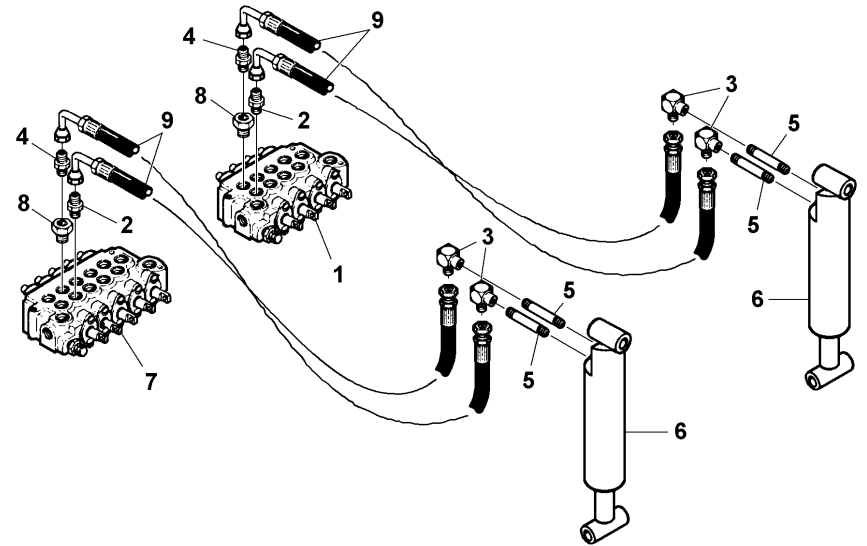

REF. NO.	NO. REQ'D	PART NUMBER	DESCRIPTION
1	REF.	REF.	CONTROL VALVE
2	2	0300044	CONNECTOR, 6MJ-8MB
3	4	0300689	STREET ELBOW, STEEL, 8MJ-8FP90
4	2	0301522	CONNECTOR, 6MJ-6MB
5	4	0301819	NIPPLE, BLACK PIPE, 1/2" X 4-1/2"
6	2	0302616	HYDRAULIC CYLINDER
7	REF.	REF.	CONTROL VALVE
8	2	0303017	CONNECTOR, 8MB-6FB
9	2	0303175	HOSE ASSEMBLY, 102"

Section VI - PARTS (cont'd)

HYDRAULIC CYLINDERS

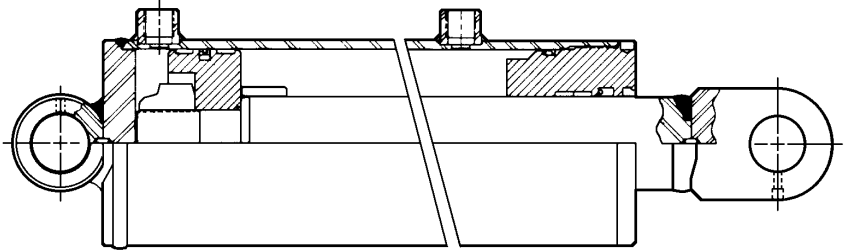

BOOM ELEVATION CYLINDER

REF. NO.	NO. REQ	PART NUMBER	DESCRIPTION
1	2	0303091	CYLINDER, BOOM ELEVATION (COMPLETE)
2	1	030xxxx	SEAL KIT, BOOM ELEVATION CYLINDER

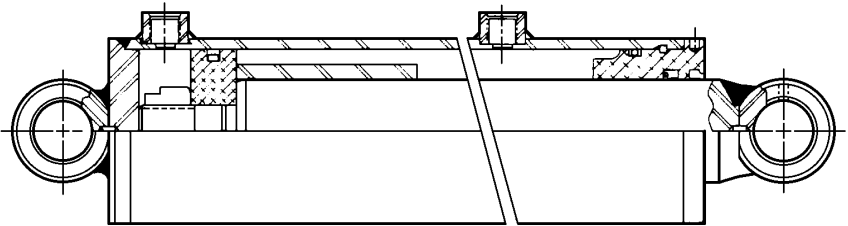

BOOM EXTENSION CYLINDER

REF. NO.	NO. REQ	PART NUMBER	DESCRIPTION
1	1	0302614	CYLINDER, BOOM EXTENSION (COMPLETE)
2	1	0304503	SEAL KIT, BOOM EXTENSION CYLINDER

Section VI - PARTS (cont'd)

HYDRAULIC CYLINDERS

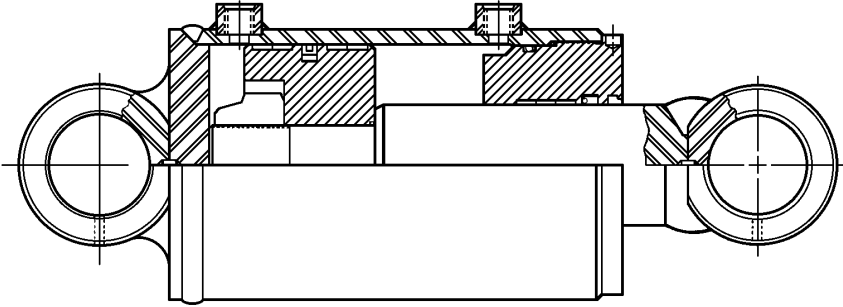

UNDERLIFT TILT CYLINDER

REF. NO.	NO. REQ	PART NUMBER	DESCRIPTION
1	1	0302791	CYLINDER, UNDERLIFT TILT (COMPLETE)
2	1	0304488	SEAL KIT, UNDERLIFT TILT CYLINDER

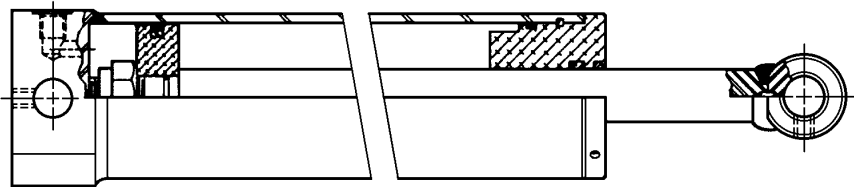

UNDERLIFT EXTENSION CYLINDER

REF. NO.	NO. REQ	PART NUMBER	DESCRIPTION
1	1	0303331	CYLINDER, UNDERLIFT EXTENSION (COMPLETE)
2	1	030xxx	SEAL KIT, UNDERLIFT EXTENSION CYLINDER

Section VI - PARTS (cont'd)

HYDRAULIC CYLINDERS

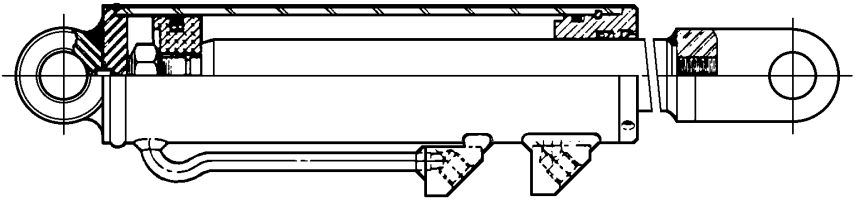

UNDERLIFT FOLD CYLINDER

REF. NO.	NO. REQ	PART NUMBER	DESCRIPTION
1	1	0301765	CYLINDER, UNDERLIFT FOLD (COMPLETE)
2	1	0304244	SEAL KIT, UNDERLIFT FOLD CYLINDER

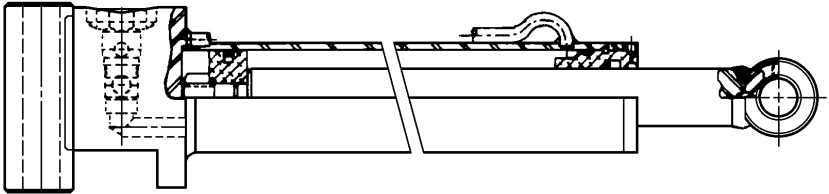

REAR SPADE CYLINDER

REF. NO.	NO. REQ	PART NUMBER	DESCRIPTION
1	2	0302616	CYLINDER, REAR SPADE (COMPLETE)
2	1	0304244	SEAL KIT, REAR SPADE CYLINDER

Section VI - PARTS (cont'd)

GLAD HAND KIT

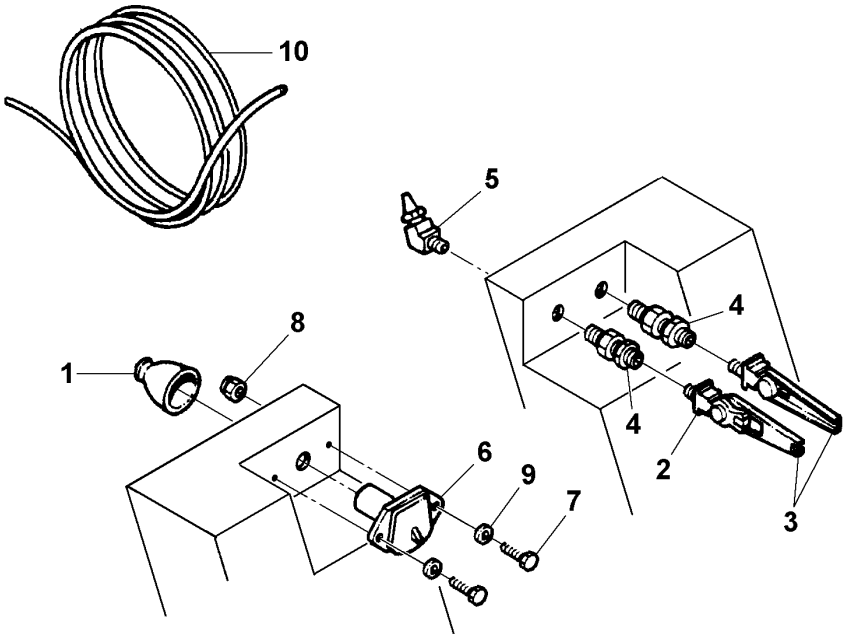

REF. NO.	NO. REQ'D	PART NUMBER	DESCRIPTION
1	1	0301909	RECEPTACLE BOOT
2	2	0301944	GLAD HAND COUPLING
3	2	0301945	GLAD HAND PLUG
4	2	0301946	BULKHEAD CONNECTOR
5	2	0301947	ADAPTER, 1/4" NPM X 3/8" SYN. HOSE
6	1	0301948	HD 7-WAY TRAILER CONNECTOR
7	2	0400070	SCREW, 1/4"-20 X 1" HEX HD CAP
8	2	0400367	NUT, 1/4"-20 NYLON HEX
9	2	0400451	FLATWASHER, 1/4"
10	2	0703795	HOSE, 3/8" X 48" SYNTHETIC

Section VI - PARTS (cont'd)

LIFT ADAPTERS

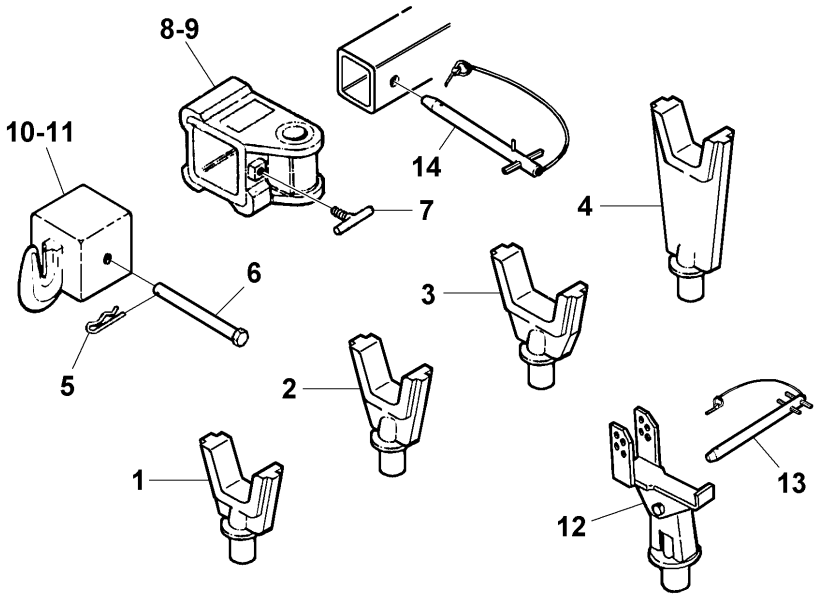

REF. NO.	NO. REQ	PART NUMBER	DESCRIPTION
1	2	0200018	FORK, SHORT (3" OPENING)
2	2	0200020	FORK, MEDIUM (3" OPENING)
3	2	0200021	FORK, MEDIUM (4-1/2" OPENING)
4	2	0200023	FORK, LONG (4-1/2" OPENING)
5	2	0400585	HAIR PIN COTTER, 1-1/4"
6	2	0711001	BOLT, MODIFIED 5/8"-11 X 5" WITH HOLE
7	2	0800590	TEE HANDLE, FORK ADAPTER
8	1	0802249	FORK ADAPTER, LT
9	1	0802250	FORK ADAPTER, RT
10	1	0802251	CHAIN HOOK ADAPTER, RT
11	1	0802252	CHAIN HOOK ADAPTER, LT
12	2	0802810	PIVOT SPRING LIFT BRACKET
13	2	0902321	RETAINING PIN, SPRING LIFT BRACKET
14	2	0902378	RETAINER PIN ASSEMBLY

Section VI - PARTS (cont'd)

OUTER CROSSTUBE ASSEMBLY

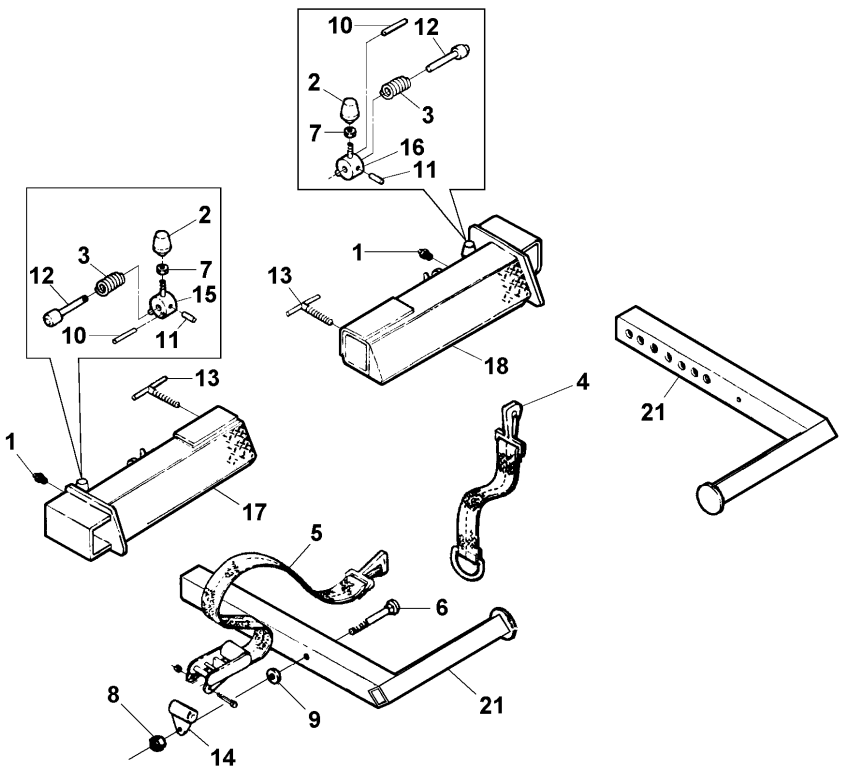

Section VI - PARTS (cont'd)

OUTER CROSSTUBE ASSEMBLY

REF. NO	NO. REQ'D	PART NUMBER	DESCRIPTION
1	2	0300113	GREASE FITTING
2	2	0300341	KNOB, "L" BAR LOCK CONTROL
3	2	0301417	SPRING, PLUNGER PIN
4	2	0301681	EXTENSION, TIRE RESTRAINT
5	2	0301682	TIRE RESTRAINT
6	2	0400269	BOLT, 5/8"-11 X 4-1/2" CARRIAGE
7	2	0400393	NUT, 3/8"-16 HEX JAM
8	2	0400421	NUT, 5/8"-11 HEX NYLOK
9	2	0400506	WASHER, 5/8" FLAT
10	2	0400559	PIN, 3/16" X 1" ROLL
11	2	0400560	PIN, 5/32" X 1" ROLL
12	2	0706688	PIN, PLUNGER
13	4	0800590	HANDLE, "T"
14	2	0800839	BRACKET, RESTRAINT ASSEMBLY PIVOT
15	1	0802069	HANDLE, L.H. PLUNGER PIN
16	1	0802070	HANDLE, R.H. PLUNGER PIN
17	1	0802231	CROSSBAR, LEFT OUTER
18	1	0802232	CROSSBAR, RIGHT OUTER
19	2	0802606	TIRE RESTRAINT, MEDIUM

Section VI - PARTS (cont'd)

KING PIN ADAPTER

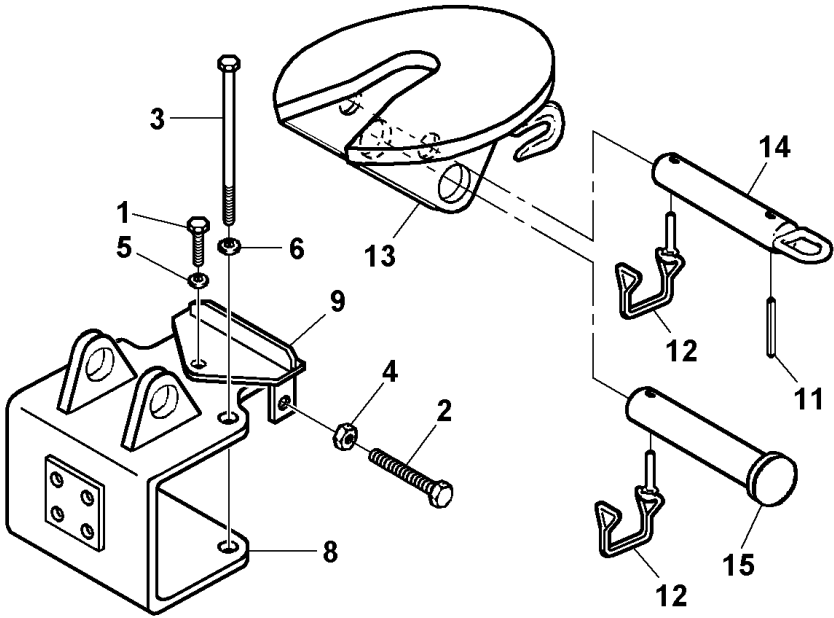

REF. NO.	NO. REQ'D	PART NUMBER	DESCRIPTION
1	1	0400188	SCREW, 1/2"-13 X 2" HEX HD CAP
2	2	0400282	SCREW, 3/4"-10 X 2-3/4" HEX HD CAP
3	2	0400316	SCREW, 7/8"-9 X 8" HEX HD CAP
4	2	0400440	NUT, 3/4"-10 HEX JAM
5	1	0400491	LOCKWASHER, 1/2" HELICAL
6	2	0400515	LOCKWASHER, 7/8" HELICAL
7	1	0706623	ADAPTER, TRAILER KING PIN (NOT SHOWN)
8	1	0802961	BRACKET WELDMENT
9	1	0802962	LOCK PLATE WELDMENT
-	1	0902782	FIFTH WHEEL ADAPTER (COMPLETE)
10	1	0400303	SCREW, 7/8"-9 X 2-1/2" HEX HD CAP
11	1	0400555	ROLL PIN, 3/8" X 1-1/2"
12	2	HD1259	PIN, SNAPPER
13	1	VA0660	5TH WHEEL PIVOT PLATE WELDMENT
14	1	VA0661	PULL PIN WELDMENT
15	1	VA0662	PIVOT PIN WELDMENT

Section VI - PARTS (cont'd)

LIGHT KIT

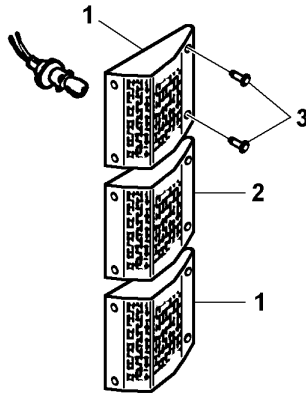
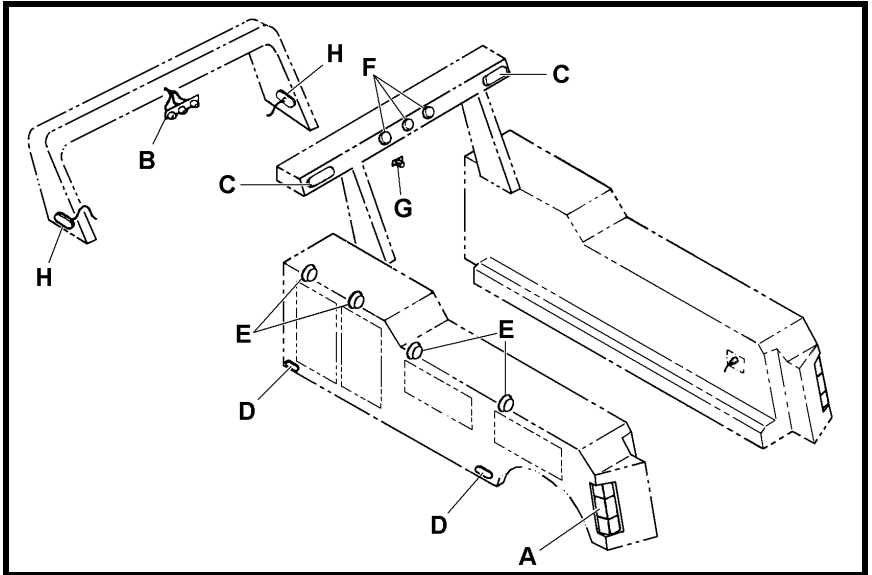

(A) STOP/TURN/BACKUP LIGHTS

REF. NO.	NO. REQ'D	PART NUMBER	DESCRIPTION
1	4	0302542	LIGHT, STOP & TURN (COMPLETE)
2	2	0302543	LIGHT, BACKUP (COMPLETE)
3	24	0400025	SCREW, # 8-32 X 3/4" RD HD SLOTTED

Section VI - PARTS (cont'd)

LIGHT KIT

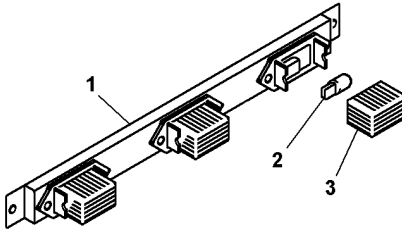

(B) 3-LIGHT BAR

REF. NO.	PART NUMBER	DESCRIPTION
1	0300442	3-LIGHT BAR ASSEMBLY, COMPLETE
2	0300507	BULB, MARKER LIGHT
3	0300511	LENS, 3-LIGHT BAR

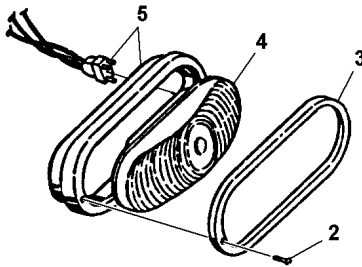

(C) STOP & TURN LIGHT

REF. NO.	PART NUMBER	DESCRIPTION
1	0301390	LIGHT, TURN (COMPLETE)
2	0304123	BEZEL MOUNTING SCREW
3	0304124	CHROME BEZEL
4	0304125	LENS & BULB ASSEMBLY
5	0304126	GROMMET & PLUG KIT

Section VI - PARTS (cont'd)

LIGHT KIT



(D) FLOOD LIGHT

REF. NO.	PART NUMBER	DESCRIPTION
1	0302201	LIGHT, FLOOD (COMPLETE)

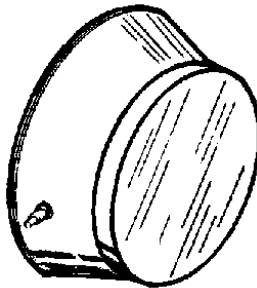

(E) DOME LIGHT

REFD. NO.	PART NUMBER	DESCRIPTION
1	0302544	LIGHT, DOME (COMPLETE)

Section VI - PARTS (cont'd)

LIGHT KIT

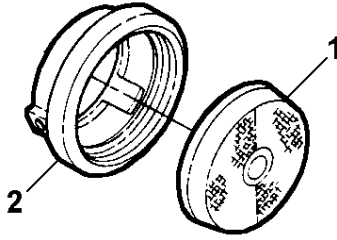

(F) MARKER LIGHTS

REF. NO.	PART NUMBER	DESCRIPTION
1	0301740	GROMMET & PLUG, MARKER LIGHT
2	0301741	SEALED MARKER LIGHT, RED
	0301742	SEALED MARKER LIGHT, AMBER

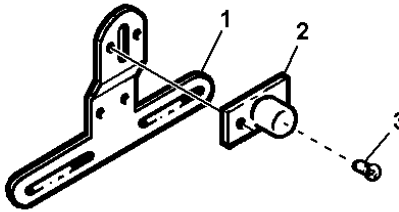

(G) LICENSE PLATE BRACKET & ILLUMINATOR

REF. NO.	PART NUMBER	DESCRIPTION
1	0300076	BRACKET, LICENSE PLATE
2	0300273	LICENSE PLATE ILLUMINATOR (COMPLETE)
3	0300512	BULB, LICENSE PLATE ILLUMINATOR

Section VI - PARTS (cont'd)

LIGHT KIT



(H) OVAL MARKER LIGHT

REF. NO.	PART NUMBER	DESCRIPTION
1	0302611	LIGHT, AMBER MARKER (COMPLETE)

CENTURY®

Miller Industries Towing Equipment Inc.

8503 Hilltop Drive • Ooltewah, Tennessee 37363 • (423) 238-4171

Telex: 856967 CENWKRTN UD