



OWNER'S MANUAL

804 MODULAR

PARTS

**NOTE: MANUAL including SPECIFICATIONS, subject to change without notice.
All ratings specified are based on structural factors only,
not vehicle capacities or capabilities.**



Miller Industries Towing Equipment Inc.
8503 Hilltop Drive
Ooltewah, Tennessee 37363
Phone (423) 238-4171 • FAX (423) 238-5371

FORM NO. 0501740
02 / 2010
PRICE \$25.00

LIMITED WARRANTY

MILLER INDUSTRIES TOWING EQUIPMENT INC., hereinafter referred to as MILLER, warrants to the original purchaser that each new MILLER wrecker or other MILLER products will be free from defects in material and workmanship for a period of twelve (12) months from date placed in service, but in no event shall such warranty period exceed twenty-four (24) months from date of manufacture by MILLER. The purchaser must promptly notify MILLER in writing of any failure in material or workmanship. In no event shall MILLER accept such notification later than twenty-four (24) months from date of delivery or twelve (12) months from date placed in service, whichever is earlier.

MILLER's obligation under this warranty, statutory or otherwise, is limited to the repair or replacement at the MILLER factory, or at a point designated by MILLER, of such part or parts as shall appear upon inspection by MILLER to be defective in material or workmanship. New or remanufactured parts will be used for any replacement at MILLER's option. This warranty is not transferable. This warranty does not obligate MILLER to bear the cost of labor or transportation charges in connection with the repair or replacement of any parts found to be defective, nor shall it apply to a product upon which repairs or alterations have been made unless authorized by MILLER.

EXCEPT AS EXPRESSLY SET FORTH IN THIS WARRANTY, MILLER MAKES NO OTHER WARRANTY, EXPRESS OR IMPLIED, AND HEREBY DISCLAIMS ALL OTHER WARRANTIES INCLUDING, BUT NOT LIMITED TO, THE IMPLIED WARRANTIES OF MERCHANTABILITY AND FITNESS FOR A PARTICULAR PURPOSE. MILLER shall in no event be liable for claimed downtime, claimed loss of profits or goodwill, or any other special, incidental, indirect, or consequential damages concerning or relating to any product or parts, whether based on negligence, strict liability, breach of contract, breach of warranty, misrepresentation or any other legal theory, regardless of whether the loss resulted from any general or particular requirement which MILLER knew or had reason to know about at the time of sale.

MILLER MAKES NO WARRANTY, EXPRESS OR IMPLIED, AS TO THE FINISHED PRODUCTS MANUFACTURED OR SUPPLIED BY ANOTHER MANUFACTURER AND SUPPLIED BY MILLER TO PURCHASER, including, but not limited to, any vehicle to which a MILLER product may be affixed or any accessories or wire rope, and MILLER EXPRESSLY DISCLAIMS ANY IMPLIED WARRANTIES OF MERCHANTABILITY OR FITNESS FOR A PARTICULAR PURPOSE AS TO SUCH EQUIPMENT OR PRODUCTS. This language shall in no way affect or diminish the rights of the purchaser to rely on such warranties as are extended by such manufacturers or suppliers. MILLER shall, to the extent permitted under applicable law, pass on to the purchaser such manufacturer's or seller's warranty.

MILLER, whose policy is one of continuous improvement, reserves the right to improve its products through changes in design or materials as it may deem desirable without being obligated to incorporate such changes in products previously sold. This warranty is not intended to cover or include the following items, which are set forth by way of example and not limitation:

- A. Normal deterioration of trim, paint, lettering, and appearance items due to wear or exposure to weather, road conditions, road treatments, etc.
- B. Any damage or defect due to accident, misuse, abuse, improper or unauthorized repairs, failure to provide reasonable and necessary maintenance, or uses for which the equipment was not designed or intended.
- C. Alterations or modifications that affect performance, operation or reliability.
- D. Normal maintenance parts including, but not limited to, wear pads, bushings, wire rope, mud flaps, fenderettes, light bulbs, hydraulic oil, filters, and tow sling belts.

IT IS EXPRESSLY UNDERSTOOD THAT MILLER MAKES NO IMPLIED WARRANTY THAT MILLER PRODUCTS SHALL BE FIT FOR THE PURPOSE OF LIFTING OR MOVING PEOPLE OR FOR ANY OTHER IMPROPER USE.



Miller Industries Towing Equipment Inc.
8503 Hilltop Drive
Ooltewah, Tennessee 37363
Telephone (423) 238-4171

SERIAL NUMBER

OWNER, USER AND OPERATOR:

We appreciate your choice of our towing and recovery unit for your application. Our number one priority is user safety which is best achieved by our joint efforts. We feel that you can make a major contribution to safety if you, as the equipment owner and operator:

1. **Comply with Federal, State, and Local Regulations.**
2. **Read, Understand, and Follow the Instructions in this Manual.**
3. **Use Good, Safe Work Practices in a Common Sense Way.**
4. **Only have Authorized and Trained Personnel performing maintenance on the Towing and Recovery Unit.**

TABLE OF CONTENTS

It is assumed by the manufacturer that the Owner/Operator has a thorough knowledge of the accepted and lawful retrieval and towing methods as dictated by his city, county or state. The manufacturer rejects any liability claim that may result from the incorrect or unlawful application of its equipment.

Section I - PARTS

SUBFRAME ASSEMBLY	I-2 & I-3
BODY ASSEMBLY	I-4 & I-5
RECOVERY BOOM ASSEMBLY	I-6 & I-7
WHEEL LIFT BOOM ASSEMBLY	I-8 & I-9
CROSSBAR & OUTER CROSSTUBE ASSEMBLY	I-10 & I-11
BOOM & WHEEL LIFT HYDRAULICS	I-12 & I-13
PUMP, VALVE & FILTER HYDRAULICS	I-14 & I-15
CONTROL ASSEMBLY	I-16 & I-17
BOOM SWIVEL ASSEMBLY	I-18

Section VI - PARTS

This Section is provided by the manufacturer for the purpose of ordering any component part of the **Vulcan 804** that may be required when part replacement is necessary. Be certain to use only original equipment replacement parts for warranty purposes as well as for keeping your unit in its original state and optimum operating capacities.

When ordering replacement or spare parts be sure to provide the following information to the manufacturer's **Parts Department**.

1. **Manual Number & Date of Publication**
2. **Manual Page Number**
3. **Page Title**
4. **Reference Number of Part Desired**
5. **Part Number**
6. **Part Description**
7. **Quantity of Part Desired**

Providing this information will help ensure that the correct parts will be delivered to you in an expedient manner without delay. Should additional information be required for repair or replacement of certain components, contact your Wrecker Manufacturer Authorized Representative.

The Manufacturer reserves the right, without notice or obligation, to improve or modify their products, which may change the specifications, models and feature availability.

Section I - PARTS (cont'd)

SUBFRAME ASSEMBLY

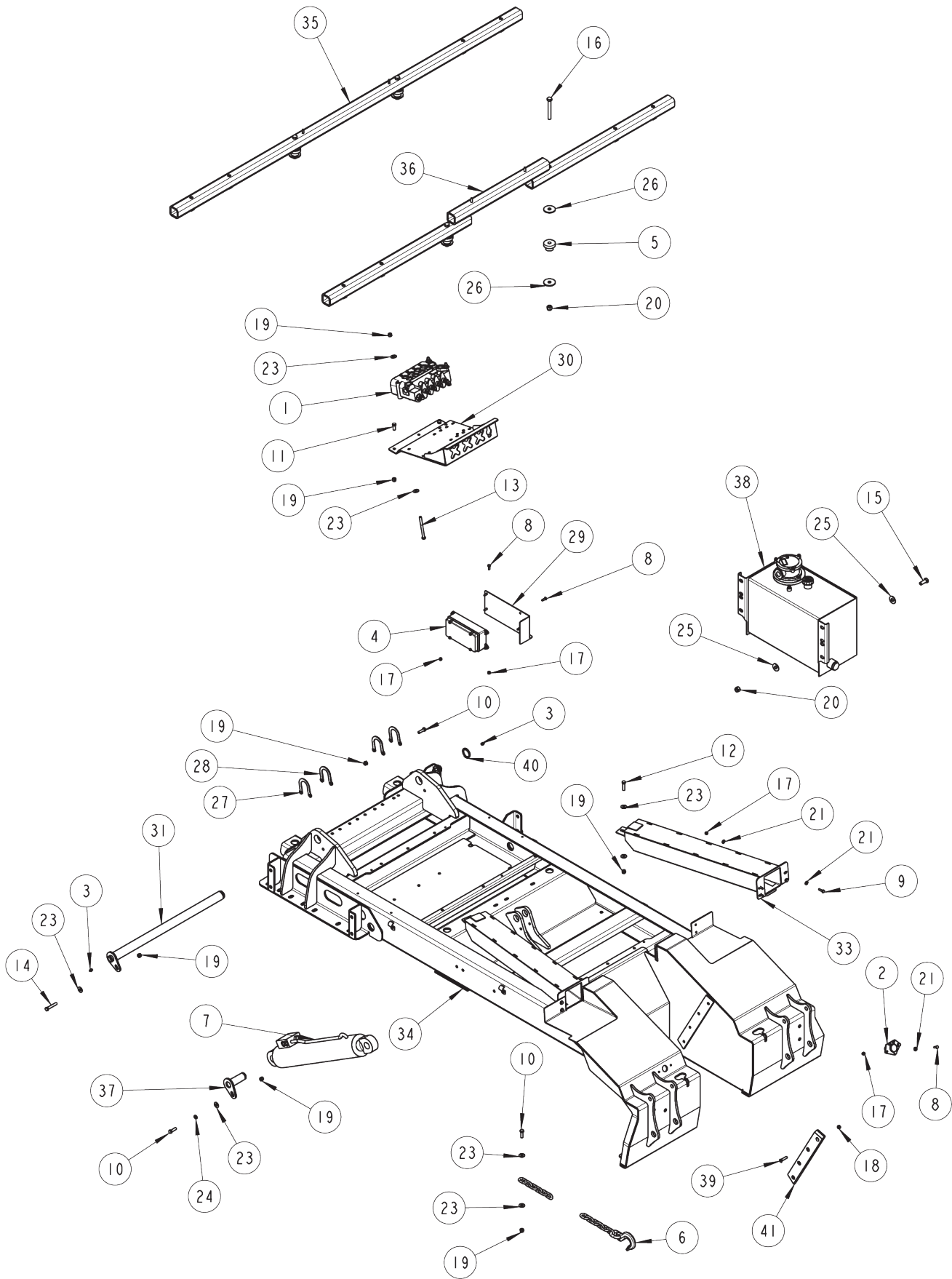

Section I - PARTS (cont'd)

SUBFRAME ASSEMBLY

ITEM	PART NUMBER	DESCRIPTION	QTY
1	0300011	VALVE, 4 SPOOL CONTROL	1
2	0301671	TOW SOCKET	1
3	0301895	GREASE FITTING, 1/8 NPT STRAIGHT	2
4	0303385	JUNCTION BOX	1
5	0306680	RUBBER "T" MOUNTS	4
6	0307383	CHAIN ASSEMBLY, 5/16" G7 X 12'	1
7	0307576	LIFT CYLINDER	1
8	0400066	1/4-20 X 3/4 HHCS GR.5,ZP	8
9	0400070	1/4-20 X 1 HHCS GR5 ZP	8
10	0400122	3/8-16 X 1 1/4 HHCS GR.5,ZP	3
11	0400126	3/8-16 X 1 HHCS GR.5,ZP	4
12	0400132	3/8-16 X 1 1/2 HHCS GR.5,ZP	2
13	0400140	3/8-16 X 4 HHCS GR.5,ZP	3
14	0400146	3/8-16 X 2-1/4 HHCS GR.5 ZP	1
15	0400209	1/2-13 X 1-1/4 HHCS GR5 ZP	4
16	0400237	1/2-13 X 4 HHCS GR 5 ZP	4
17	0400367	1/4-20 NYLOCK HEX NUT ZP	12
18	0400382	5/16-18 NYLOCK HEX NUT ZP	8
19	0400392	3/8-16 NYLOCK HEX NUT ZP	13
20	0400408	1/2-13 NYLOCK HEX NUT ZP	8
21	0400451	1/4 FLAT WASHER ZP	14
22	0400452	1/4 HELICAL LOCK WASHER ZP	4
23	0400480	3/8 FLAT WASHER ZP	14
24	0400482	3/8 HELICAL LOCK WASHER ZP	1
25	0400492	1/2 FLAT WASHER ZP	8
26	0400498	WASHER, 1/2' ID X 2" OD X .150	8
27	0719519	SHIM - BOOM PIVOT (.0747 THICK)	2
28	0719520	SHIM- BOOM PIVOT (.1196 THK)	2
29	0722941	BRACKET - JUNCTION BOX STAND	1
30	0806850	VALVE MOUNTING BRACKET WELDMENT	1
31	0807183	BOOM PIVOT PIN WELDMENT	1
32	0807214	SCOOP STORAGE WELD'T LH	1
33	0807215	SCOOP STORAGE WELD'T RH	1
34	0807230	880 SUBFRAME -NEW CONV	1
35	0807232	FRONT BODY MTG.TUBE WELD'T	1
36	0807471	REAR BODY MTG TUBE WELD'T	1
37	0807707	PIN WELDMENT	1
38	0910008	HYDRAULIC TANK ASSEMBLY	1
39	9043973	SCREW, 5/16"-16 X 1-1/2" FL HD SKT	8
40	9056150	RETAINING RING, 1-1/2"	1
41	805040011	VERTICAL BOOM GUIDE	2

Section I - PARTS (cont'd)

BODY ASSEMBLY

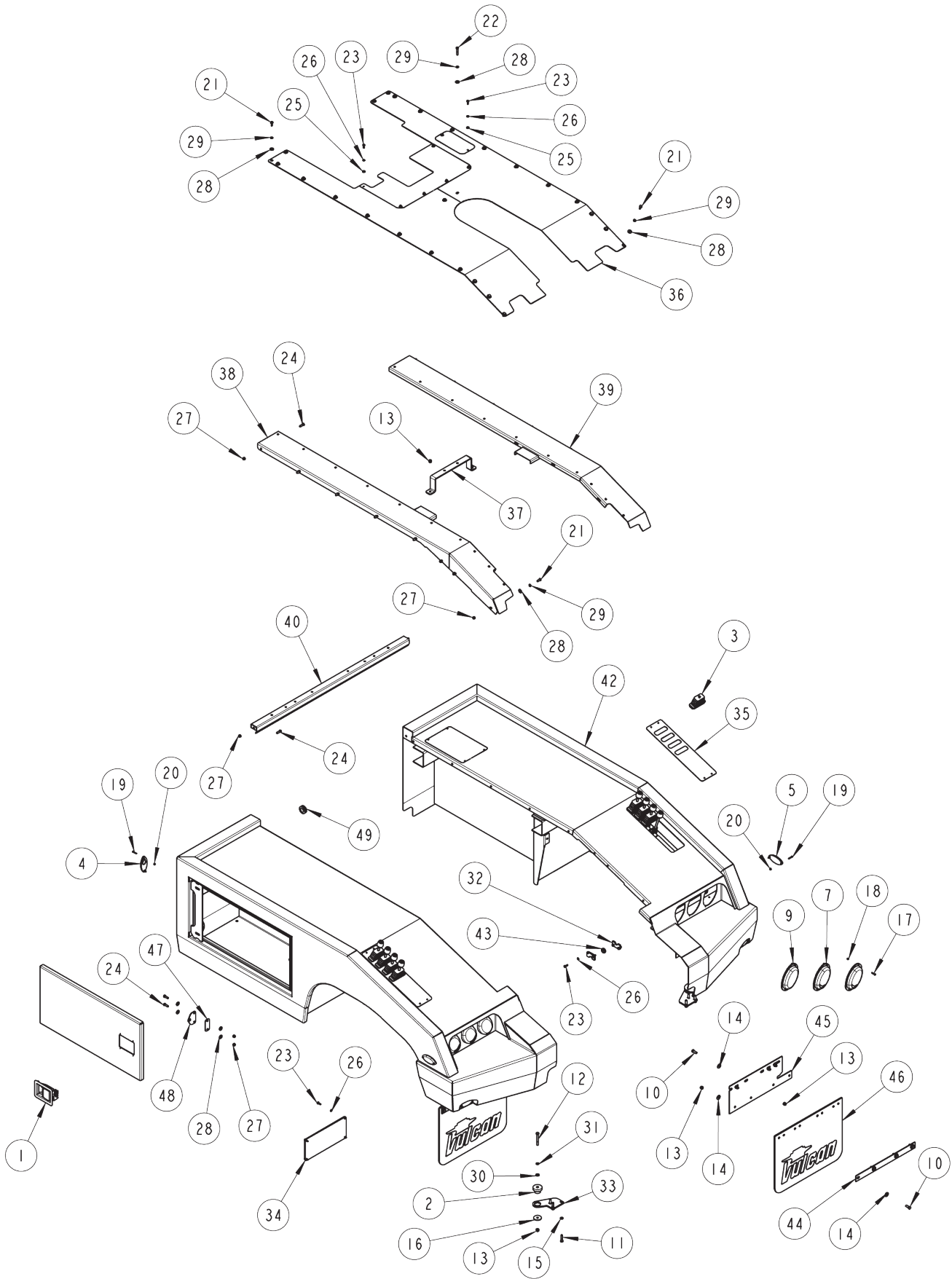

Section I - PARTS (cont'd)

BODY ASSEMBLY

ITEM	PART NUMBER	DESCRIPTION	QTY
1	0303120	PADDLE LATCH W/GASKET	2
2	0306680	RUBBER "T" MOUNTS	2
3	0310148	BOOT - CONTROL HANDLE	8
4	0310214	LAMP, LED SIDE MARKER (AMBER)	2
5	0310215	LAMP, LED SIDE MARKER (RED)	4
6	0310353	LIGHT, AGROLUN LH STOP/TAIL	2
7	0310354	LIGHT, AGROLUN RH STOP/TAIL	2
8	0310355	LIGHT, AGROLUN LH BACK-UP	1
9	0310356	LIGHT, AGROLUN RH BACK-UP	1
10	0400126	3/8-16 X 1 HHCS GR.5,ZP	16
11	0400132	3/8-16 X 1 1/2 HHCS GR.5,ZP	6
12	0400133	3/8-16 X 3 HHCS GR.5,ZP	2
13	0400392	3/8-16 NYLOCK HEX NUT ZP	20
14	0400480	3/8 FLAT WASHER ZP	24
15	0400482	3/8 HELICAL LOCK WASHER ZP	6
16	0400484	3/8 X 1-3/4 X 1/8 THICK FLAT WASHER ZP	2
17	0400686	#10-24 X 1" PAN HEAD PHILLIPS	12
18	0400688	#10-24 NYLOCK HEX NUT SS	12
19	0400689	SCREW, #8-32 X 1/2" FL HD PH MACH	12
20	0400690	NUT, #8-32 HEX NYLOK	12
21	0400823	5/16-18 X 3/4 LG HHCS SS	30
22	0400824	5/16-18 X 3/4 LG HHCS SS	2
23	0402020	1/4-20 X 3/4 HHCS SS	24
24	0402032	5/16 X 1 HHCS SS	16
25	0402110	1/4 FLATWASHER 316 STAINLESS	8
26	0402111	1/4 LOCKWASHER 316 STAINLESS	24
27	0402116	5/16"-18 NC HEX NYLOK NUT SS	22
28	0402117	5/16 FLATWASHER 316SS	40
29	0402118	5/16 HELICAL LOCK WASHER SS	32
30	0402120	3/8 FLATWASHER 316 SS	2
31	0402121	3/8 LOCKWASHER 316 STAINLESS	2
32	0719710	SPLIT HARNESS PLATE	4
33	0719921	BODY / SUBFRAME MTG. PLATE	2
34	0721514	TAIL LIGHT INSPECTION COVER PLATE	2
35	0722061	PLATE - 4 FUNCTION CONTROL COVER	2
36	0807249	804 CENTER COVER WELDMENT	1
37	0807250	804 CENTER COVER SUPPORT WELDMENT	1
38	0807319	LH 94" WIDE DECK MTG. ANGLE WELDMENT	1
39	0807320	RH 94" WIDE DECK MTG. ANGLE WELDMENT	1
40	0807326	FRONT DK MTG. CROSSMEMBER WELD'T	1
41	0807415	LH C.S. BODY WELDMENT	1
42	0807416	RH C.S. BODY WELDMENT	1
43	9032053	GROMMET	2
44	804500001	MUD FLAP BACK-UP STRIP	2
45	806070010	MUD FLAP EXTENSION PLATE	2
46	891000001	MUDFLAP	2
47	945400518	WASHER PLATE	2
48	945400800	STRIKER PIN WELD'T	2
49	GV57	RUBBER GROMMET	2

Section I - PARTS (cont'd)

RECOVERY BOOM ASSEMBLY

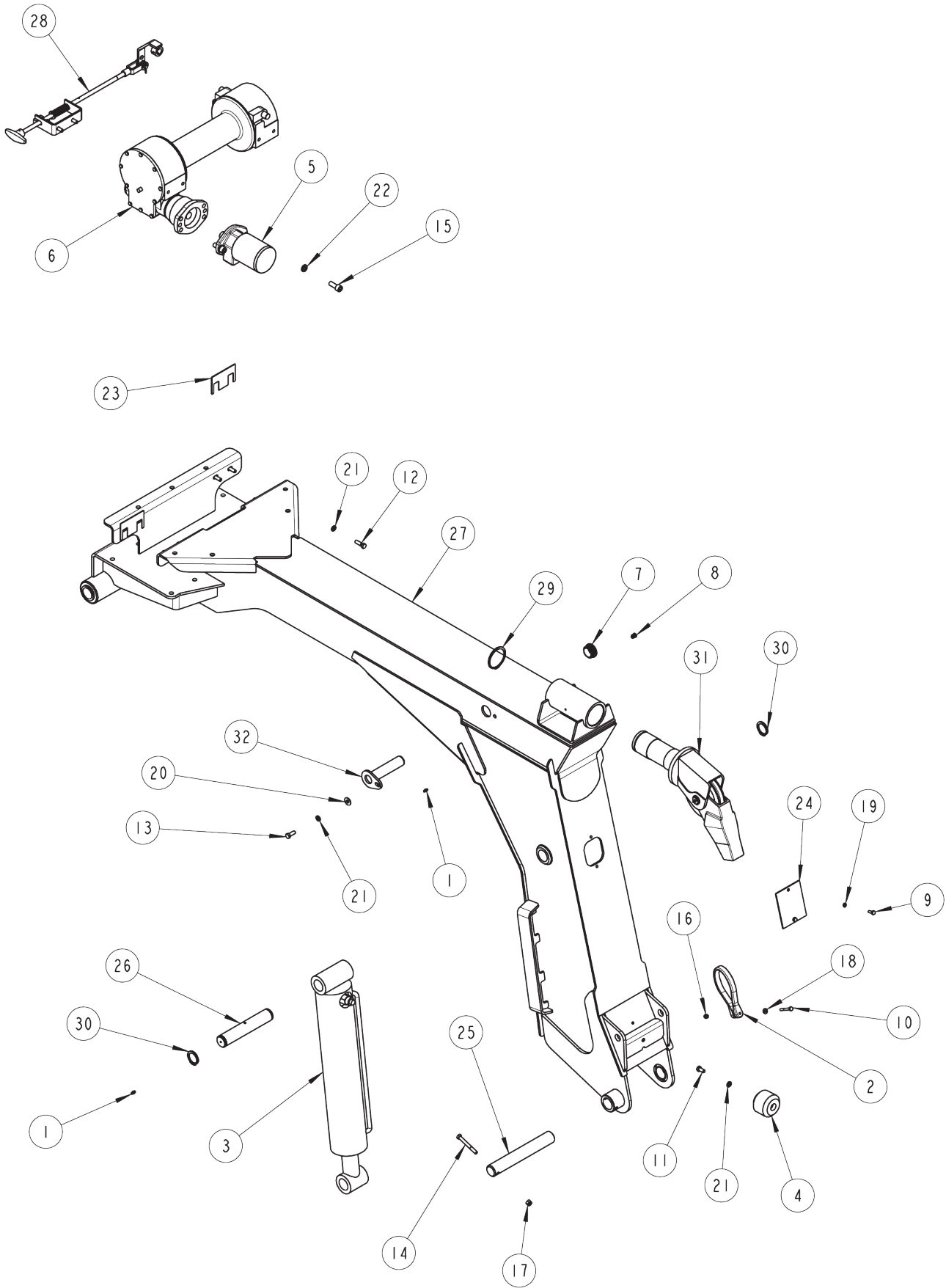

Section I - PARTS (cont'd)

RECOVERY BOOM ASSEMBLY

ITEM	PART NUMBER	DESCRIPTION	QTY
1	0300113	GREASE FITTING, 1/4-28 STRAIGHT	2
2	0301533	TIE DOWN STRAP, 15"	1
3	0302919	FOLD CYLINDER	1
4	0306688	TIMBREN SPRING	1
5	0307097	HYDRAULIC MOTOR, PARKER	1
6	0307579	WINCH ASSEMBLY, HY-246 NARROW DRUM	1
7	0307965	PLUG - 1-3/4 DIA	1
8	0307966	PLUG - 1/2 DIA	1
9	0400066	1/4-20 X 3/4 HHCS GR.5,ZP	2
10	0400078	1/4-20 X 2 HHCS GR5 ZP	1
11	0400121	3/8-16NC X 3/4 HHCS GR. B	1
12	0400122	3/8-16 X 1 1/4 HHCS GR.5,ZP	6
13	0400126	3/8-16 X 1 HHCS GR.5,ZP	1
14	0400133	3/8-16 X 3 HHCS GR.5,ZP	1
15	0400196	SCREW, 1/2"-13 X 1-1/4" SKT HD	2
16	0400367	1/4-20 NYLOCK HEX NUT ZP	1
17	0400392	3/8-16 NYLOCK HEX NUT ZP	1
18	0400451	1/4 FLAT WASHER ZP	2
19	0400452	1/4 HELICAL LOCK WASHER ZP	2
20	0400480	3/8 FLAT WASHER ZP	1
21	0400482	3/8 HELICAL LOCK WASHER ZP	8
22	0400491	1/2 HELICAL LOCK WASHER ZP	2
23	0706668	SHIM, WINCH MOUNTING	2
24	0708519	PLATE, ACCESS COVER	1
25	0717069	PIN - MIDNIGHT U/L	1
26	0718218	PIN - FOLD (BASE)	1
27	0807078	MAIN OUTER BOOM WELDMENT	1
28	0908627	WINCH FREE-SPOOL ASSY	1
29	9055275	SNAP RING, 2-3/4" EXTERNAL	1
30	9056150	RETAINING RING, 1-1/2"	2
31	805180000	SHEAVE HOUSING ASSEMBLY	1
32	880401500	PIN BOOM LIFT CYLINDER UPPER	1

Section I - PARTS (cont'd)

WHEEL LIFT BOOM ASSEMBLY

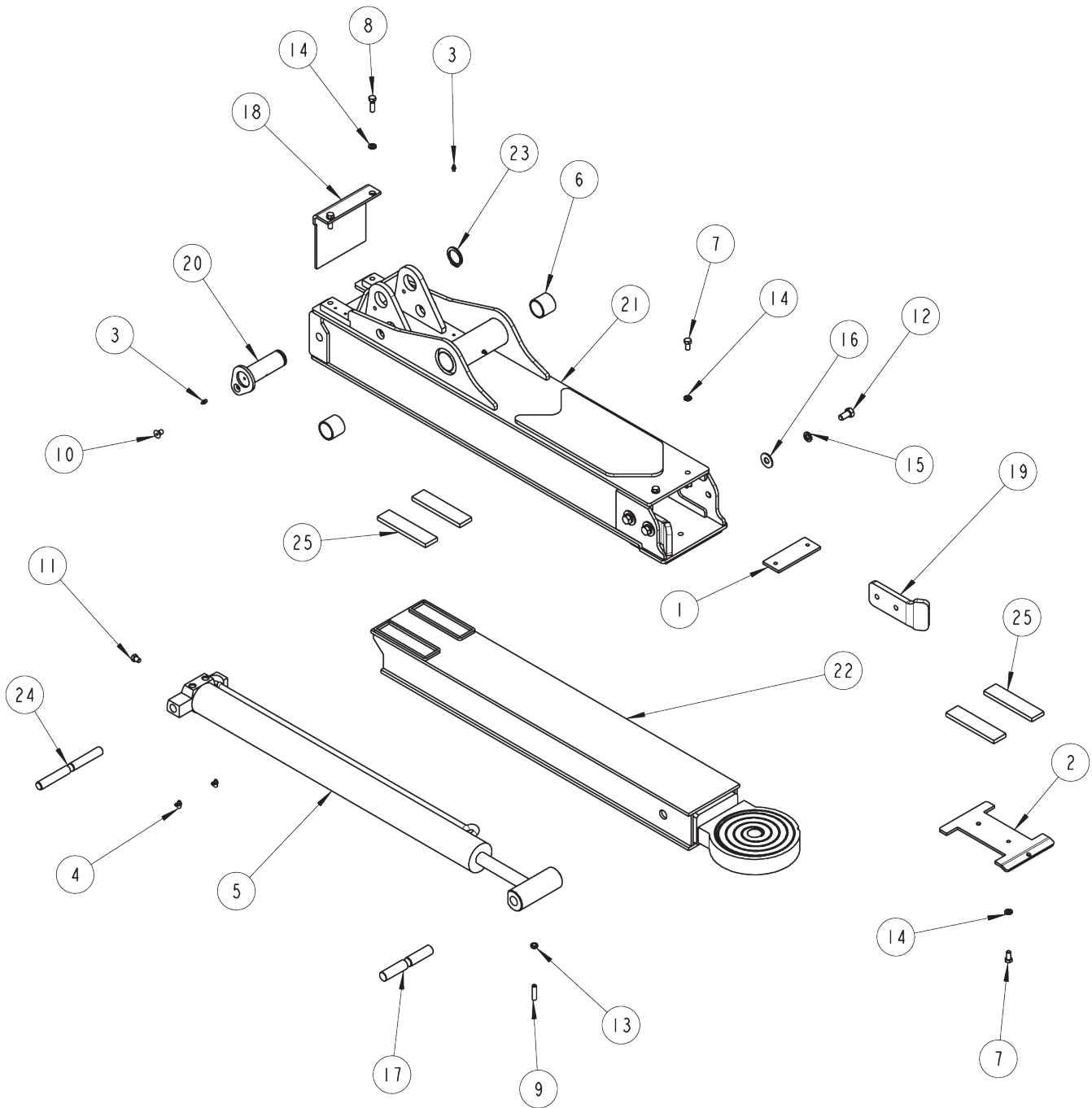

Section I - PARTS (cont'd)

WHEEL LIFT BOOM ASSEMBLY

ITEM	PART NUMBER	DESCRIPTION	QTY
1	3012-794003	BAR - SPACER	1
2	3012-794004	PLATE - UL PAD CAGE	1
3	0300113	GREASE FITTING, 1/4-28 STRAIGHT	4
4	0301397	GREASE FITTING, 90 DEG	2
5	0301825	CYLINDER HYDRAULIC EXTEND	1
6	0306942	CAST BRONZE BEARING- SLEEVE 1 1/2"	2
7	0400121	3/8-16NC X 3/4 HHCS GR. B	4
8	0400122	3/8-16 X 1 1/4 HHCS GR.5,ZP	2
9	0400139	SCREW, 3/8"-16 X 1-1/2" HEX SKT SET	1
10	0400152	SCREW, 3/8"-16 X 5/8" SKT HD SUNK	1
11	0400154	3/8-16 X 1/2 HHCS GR.5,ZP	1
12	0400217	1/2-20 X 1.00 HHCS GR8 ZP	4
13	0400398	3/8-16 NYLOCK HALF-NUT ZP	1
14	0400482	3/8 HELICAL LOCK WASHER ZP	6
15	0400491	1/2 HELICAL LOCK WASHER ZP	4
16	0400492	1/2 FLAT WASHER ZP	4
17	0718216	SHAFT- INNER TUBE CYLINDER	1
18	0718528	ANGLE - BOOM COVER	1
19	0718949	PLATE - XBAR POSITIONING	2
20	0806842	PIN WELDMENT	1
21	0807027	OUTER W/L BOOM WELDMENT	1
22	0807082	INNER UNDERLIFT BOOM WELDMENT	1
23	9056150	RETAINING RING, 1-1/2"	1
24	807500001	PIN - EXTEND	1
25	896040002	NYLATRON PAD	4

Section I - PARTS (cont'd)

CROSSBAR & OUTER CROSSTUBE ASSEMBLY

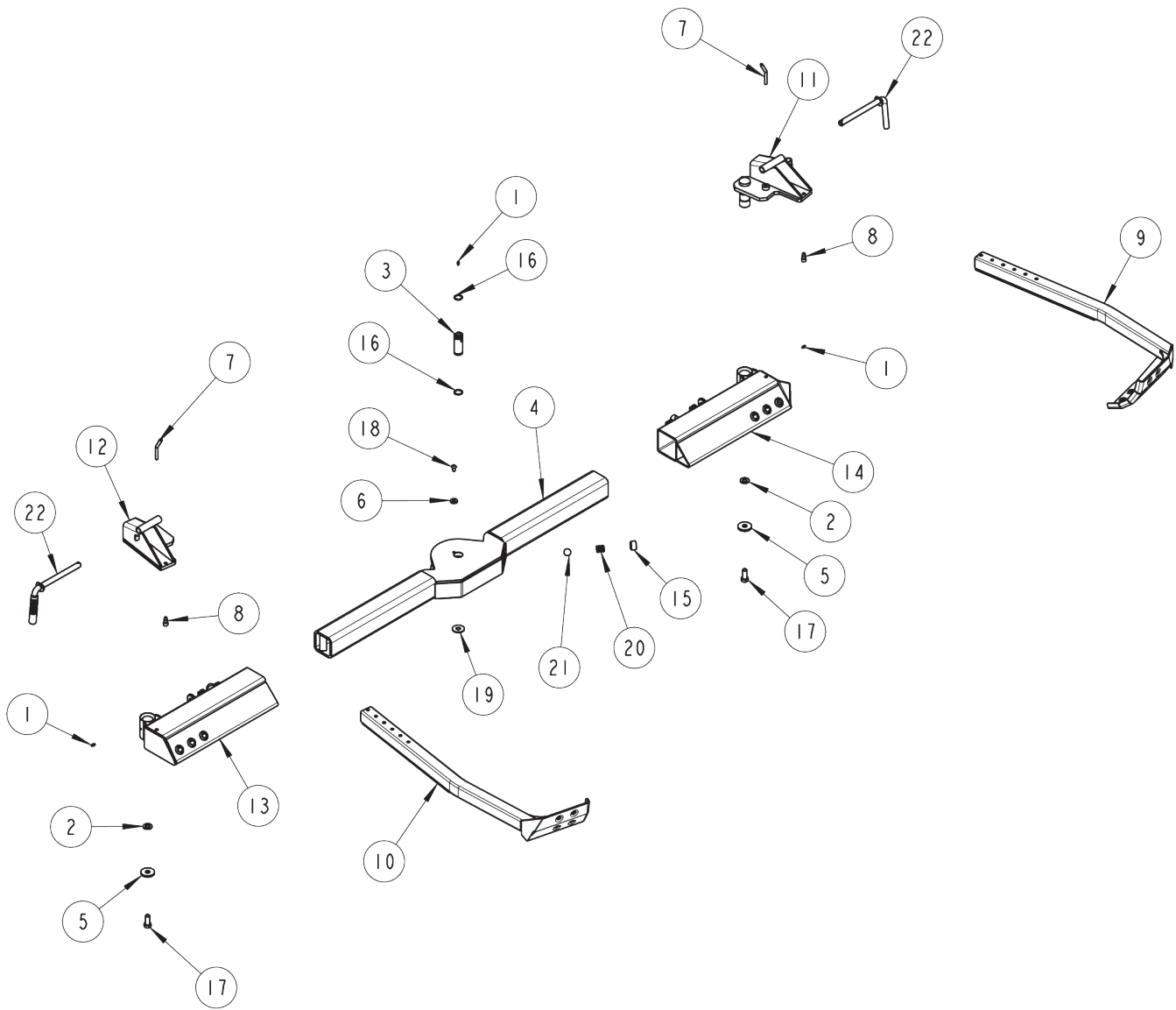

Section I - PARTS (cont'd)

CROSSBAR & OUTER CROSSTUBE ASSEMBLY

ITEM	PART NUMBER	DESCRIPTION	QTY
1	0300113	GREASE FITTING, 1/4-28 STRAIGHT	3
2	0400505	5/8 FLAT WASHER SAE	2
3	0718392	CROSSBEAM PIVOT PIN	1
4	0806899	STINGER CROSSBEAM WELD'T	1
5	8600404	WASHER	2
6	8600406	WASHER - PIVOT PIN	1
7	8602001	LOCK PIN	2
8	8700109	SCOOP PIN	2
9	8700180	WHEEL RETAINER WELD'T	1
10	8700190	WHEEL RETAINER WELD'T	1
11	8701500	SCOOP BRACKET WELD'T	1
12	8701600	SCOOP BRACKET WELD'T	1
13	8800801	LH WHEEL GRID ASSY 880	1
14	8800901	RH WHEEL GRID ASSY 880	1
15	9012944	PIPE PLUG, 1" NPT SKT HD	1
16	9030214	O-RING	2
17	9043950	5/8-11X1-1/2	2
18	9043956	3/8 NC X 3/4 BUTTON HD ALLEN	1
19	9045209	5/8" BS FLAT WASHER NON-PLATED	1
20	9047057	DETENT SPRING	1
21	9052013	BALL, 1" CHROME	1
22	880411600	FRONT STOP PIN ASSY (CROSSBAR)	2

Section I - PARTS (cont'd)

RECOVERY BOOM & WHEEL LIFT HYDRAULICS

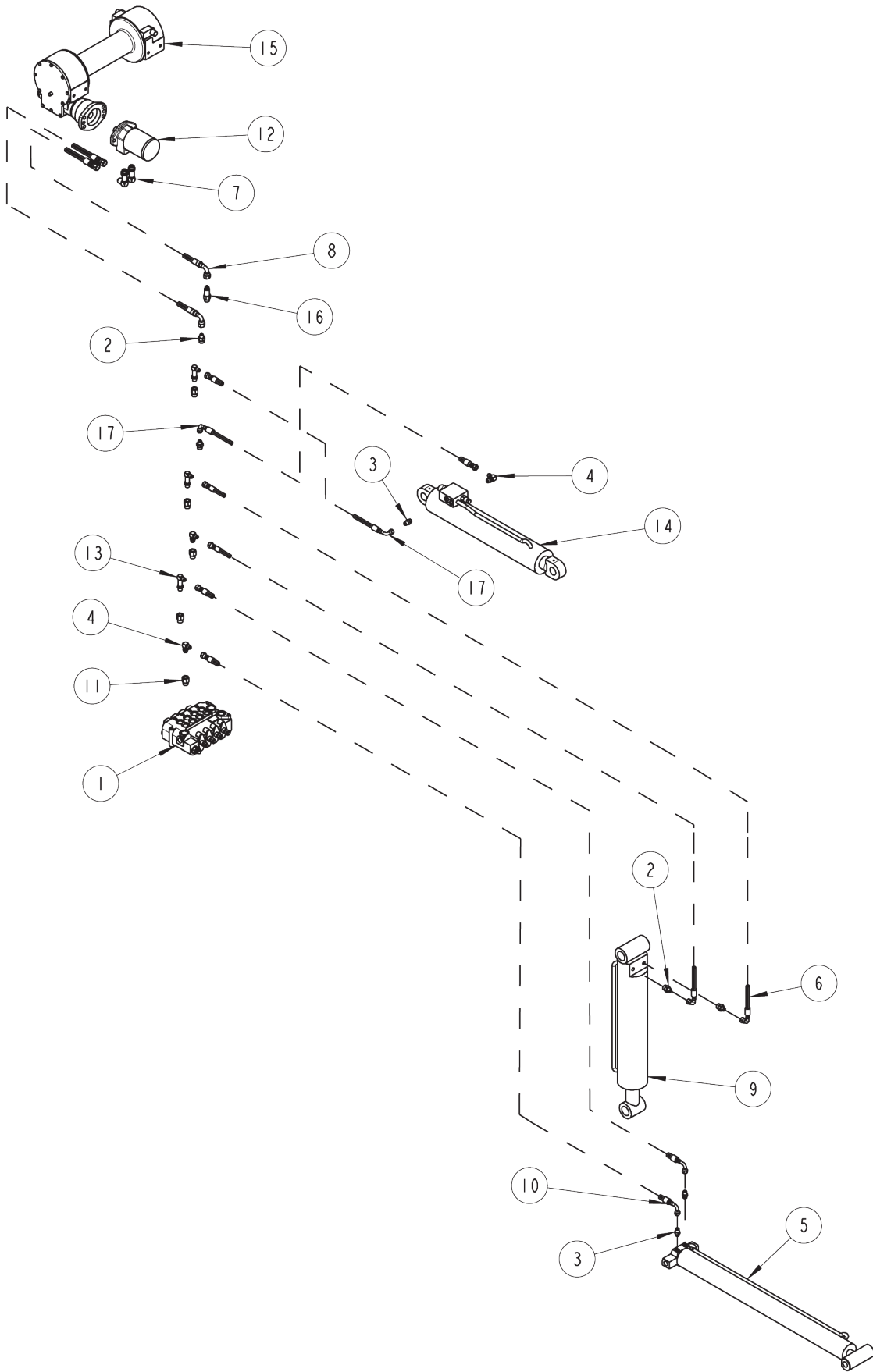

Section I - PARTS (cont'd)

RECOVERY BOOM & WHEEL LIFT HYDRAULICS

ITEM	PART NUMBER	DESCRIPTION	QTY
1	0300011	VALVE, 4 SPOOL CONTROL	1
2	0300044	CONNECTOR 6MJX8MB	4
3	0301522	CONNECTOR 6MJ-6MB	3
4	0301620	FITTING, ELBOW, 6MJ-6MB90	3
5	0301825	CYLINDER - EXTEND	1
6	0301921	HOSE ASSEMBLY, 128	2
7	0302508	ELBOW, 8MJ-8MB90LL	2
8	0302584	HOSE ASSEMBLY, 50"	2
9	0302919	FOLD CYLINDER	1
10	0302922	HOSE ASSEMBLY, 170"	2
11	0303017	CONNECTOR 8MBX6FB	5
12	0307097	HYDRAULIC MOTOR, PARKER	1
13	0307460	FITTING, ELBOW, 6MJ-6MB90L	3
14	0307576	LIFT CYLINDER	1
15	0307579	WINCH ASSEMBLY, HY-246 NARROW DRUM	1
16	0310289	CONNECTOR, 8MJ-8MBL	1
17	810770015	HOSE ASSEMBLY, 29"	2

Section I - PARTS (cont'd)
PUMP, VALVE & FILTER HYDRAULICS

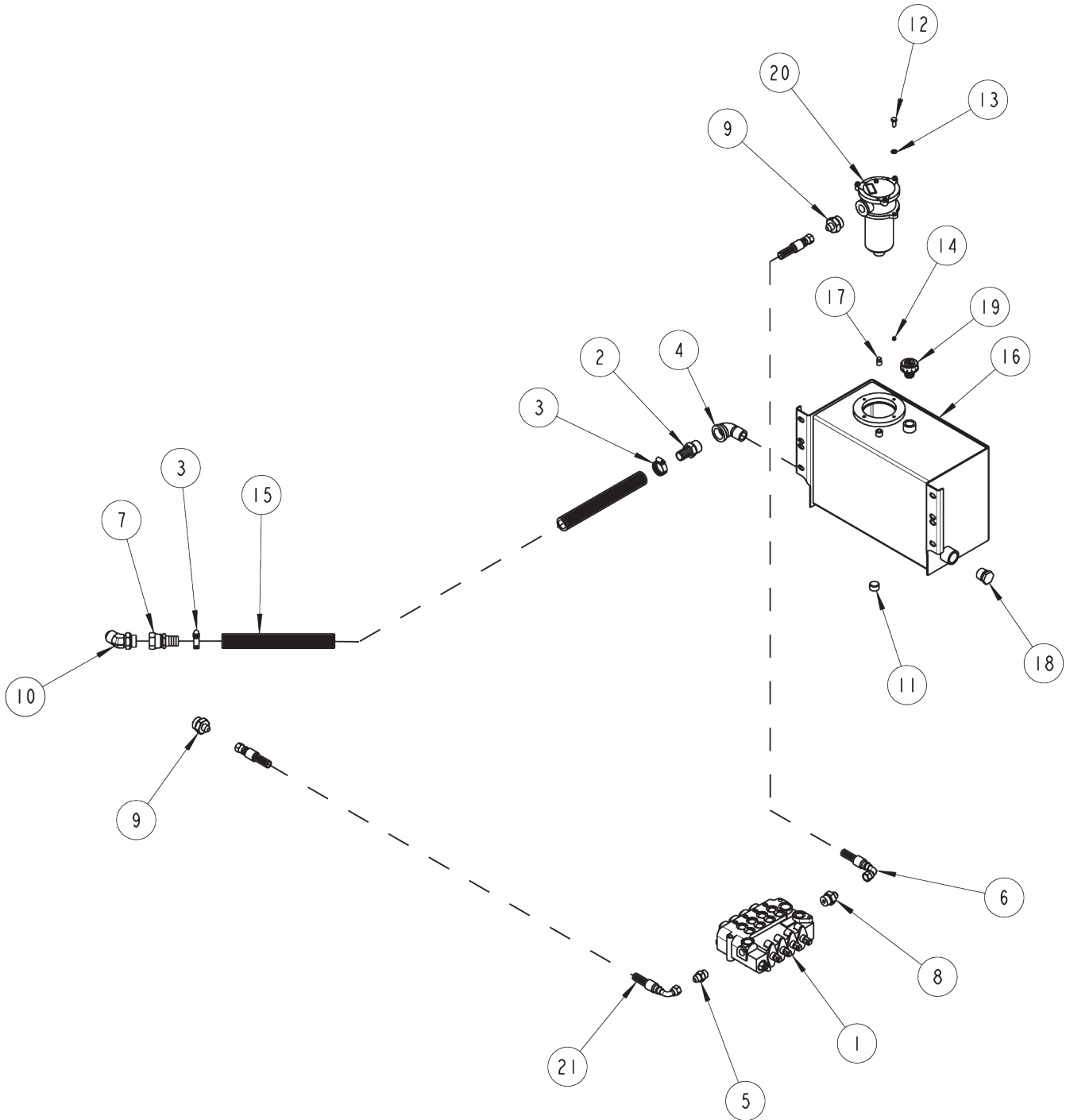

Section I - PARTS (cont'd)

PUMP, VALVE & FILTER HYDRAULICS

ITEM	PART NUMBER	DESCRIPTION	QTY
1	0300011	VALVE, 4 SPOOL CONTROL	1
2	0300056	BARB, 16C4-16MP	1
3	0300071	HOSE CLAMP, 1"	2
4	0300692	STREET ELBOW, 1" 90°	1
5	0301376	CONNECTOR 8MJX10MB	1
6	0301471	HOSE ASSEMBLY - 30" LG	1
7	0301767	BARB, 16C4-16FJX	1
8	0301780	CONNECTOR, 8MJ-12MB	1
9	0302757	CONNECTOR, 8MJ-12MB	2
10	0302761	ELBOW, 16MJ-16MB45	1
11	0310462	MAGNETIC HEX PLUG ~ 3/4 NPT	1
12	0400118	5/16-18 X 3/4 HHCS GR.5 ZP	2
13	0400464	5/16 HELICAL LOCK WASHER ZP	2
14	0400748	SCREW, 5/16"-18 X 1/4" HEX SKT SET	2
15	0702540	SUCTION HOSE, 12 FT (1" ID)	2
16	0807297	HYDRAULIC TANK WELDMENT	1
17	9011011	PIPE PLUG, 1/4" SQ HD	1
18	9012839	PLUG 1" (HYDRAULIC) HEX HEAD	1
19	9018131	BREATHER CAP	1
20	9018399	IMMERSION FILTER ASSEMBLY	1
21	880010023	HOSE ASSEMBLY-103"	1

Section I - PARTS (cont'd)

CONTROL ASSEMBLY

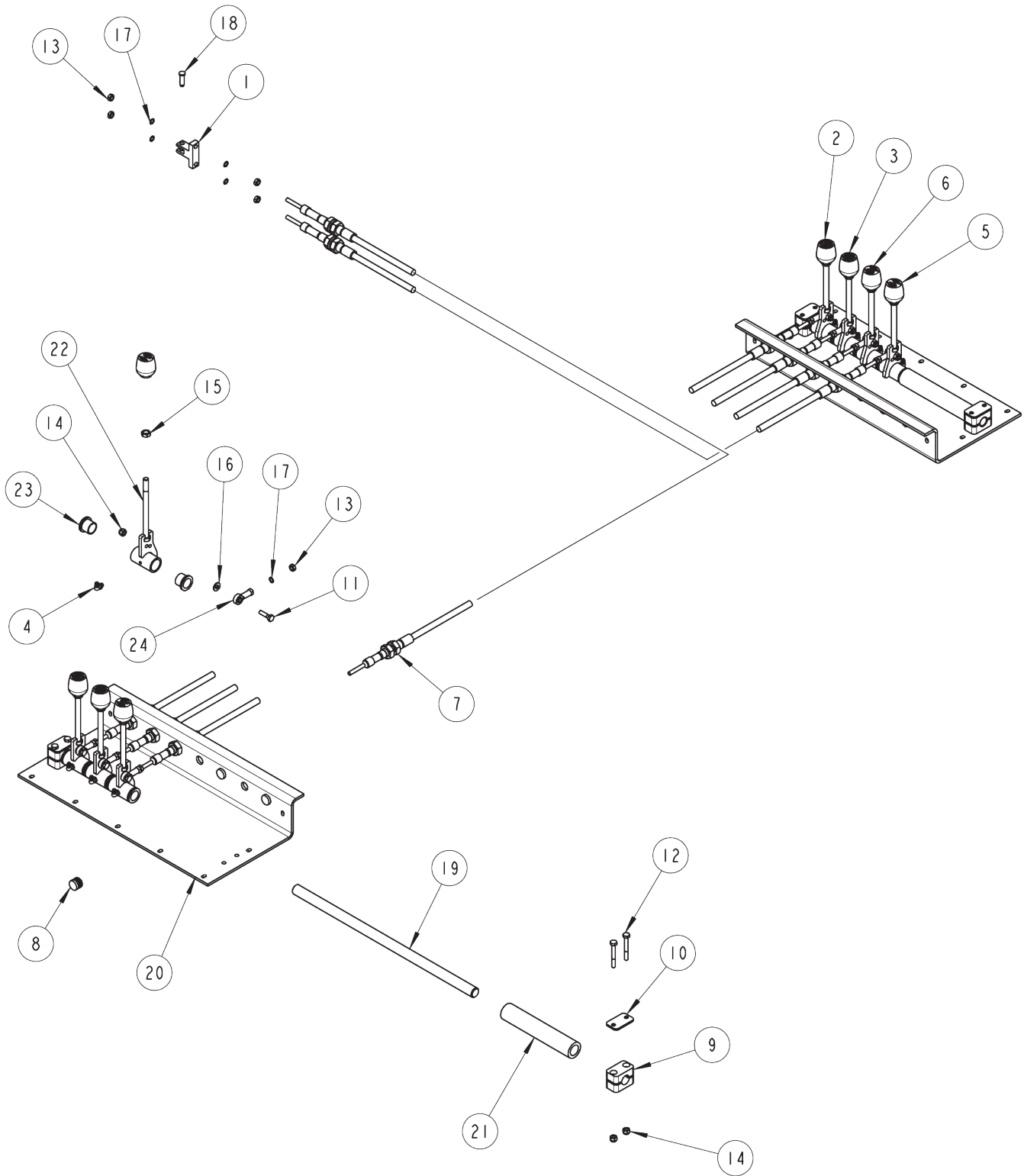

Section I - PARTS (cont'd)

CONTROL ASSEMBLY

ITEM	PART NUMBER	DESCRIPTION	QTY
1	3014-791012	CLEVIS - DUAL CTRL CABLE	1
2	0300834	KNOB, CABLE (IN-OUT)	2
3	0300835	KNOB, BOOM (UP-DN)	2
4	0301397	GREASE FITTING, 90 DEG	8
5	0302856	KNOB, TILT (UP-DN)	2
6	0302917	KNOB, WHL LIFT EXT (IN-OUT)	2
7	0307634	CONTROL CABLE 64" LG	8
8	0307772	3/4_PLUG	3
9	0307823	CLAMP CUSHION	4
10	0307824	CLAMP COVER PLATE	4
11	0400070	1/4-20 X 1 HHCS GR5 ZP	8
12	0400078	1/4-20 X 2 HHCS GR5 ZP	4
13	0400365	HEX NUT, 1/4"-28	12
14	0400367	1/4-20 NYLOCK HEX NUT ZP	12
15	0400393	3/8"-16 HEX JAM NUT	8
16	0400451	1/4 FLAT WASHER ZP	8
17	0400458	1/4 STAR LOCKWASHER ZP	12
18	0400527	CLEVIS PIN, 5/16" X 5/8" COTTERLESS	1
19	0721658	ROD CONTROL HANDLE PIVOT	2
20	0722377	PLATE- CONTROL HANDLE MOUNTING	2
21	0722379	SPACER	2
22	0806852	CONTROL HANDLE WLMT	8
23	9053524	BRONZE BUSHING (.752 X .879 X .750)	16
24	HD0900	BEARING, ROD END, 1/4-28	8

Section I - PARTS (cont'd)

BOOM SWIVEL ASSEMBLY

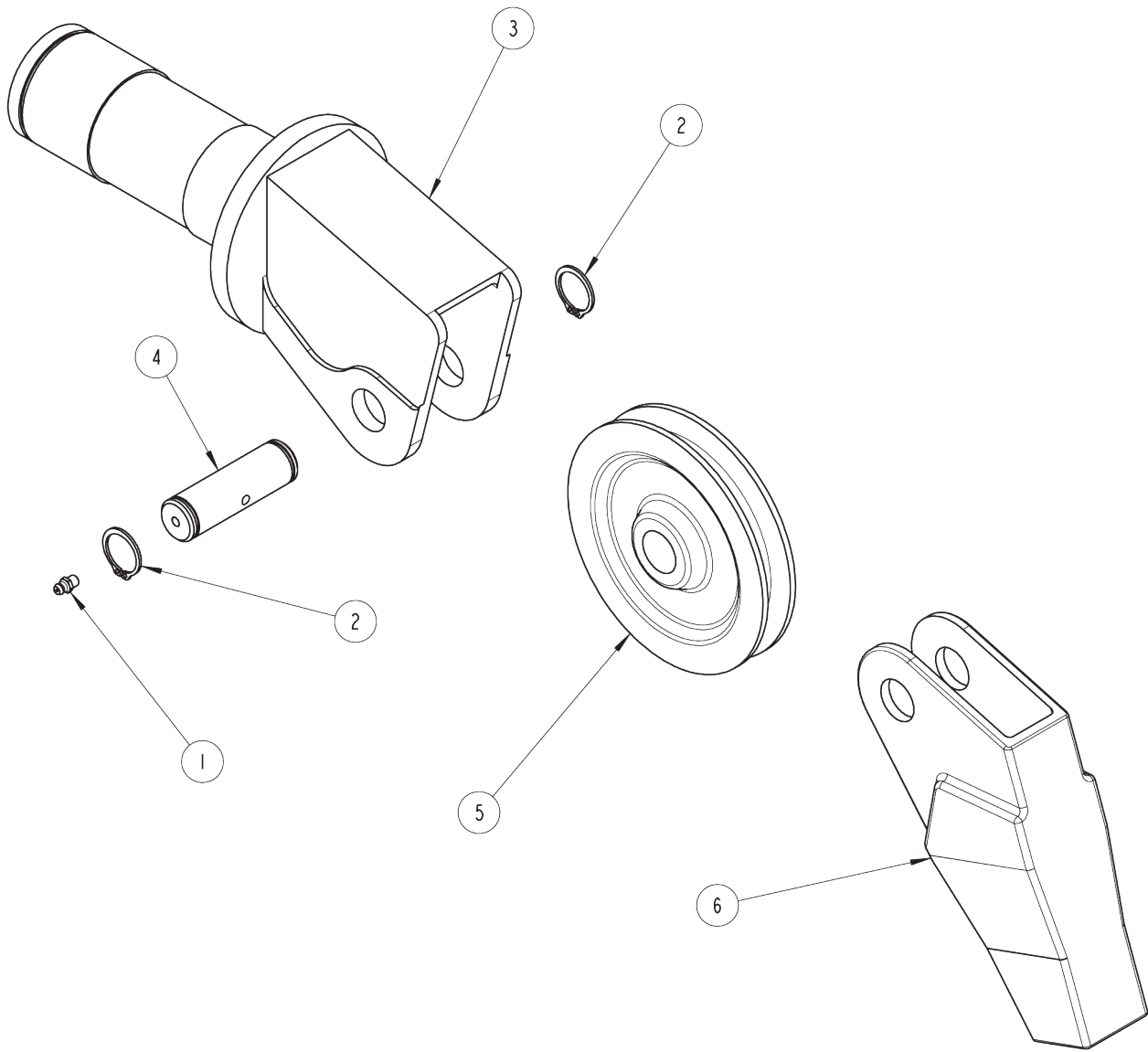

ITEM	PART NUMBER	DESCRIPTION	QTY
1	0300113	GREASE FITTING, 1/4-28 STRAIGHT	1
2	9056098	SNAP RING, 1"	2
3	804181500	SHEAVE HOUSING CASTING	1
4	805180001	SHEAVE SHAFT	1
5	805180002	SHEAVE CASTING	1
6	852060100	CABLE GUIDE CASTING	1



Miller Industries Towing Equipment Inc.
8503 Hilltop Drive • Ooltewah, Tennessee 37363 • (423) 238-4171
www.millerind.com