

# SETTING THE STANDARD IN HEAVY-DUTY TOWING & RECOVERY



4024

The 4024/T2 with over 103" of reach on the underlift is ideally suited to handle a wide variety of vehicles such as motor homes, delivery vans, and city tractors. This single axle unit with a 20-ton recovery boom and 20,000 lb. winches creates an incredible value with features only found on larger units.



5130

The 5130 is Century's Largest single axle integrated towing and recovery unit with 128" of underlift reach. The 5130 has the ability to tow most vehicles without giving up maneuverability of a single axle unit. The 5130 also provides a 25-Ton recovery boom and 25,000 lb. winches for your recovery and lifting applications.

The updated design of the aluminum modular body provides spacious tool compartments to provide industry leading storage space for your tools and equipment. Features include adjustable shelves, chain racks and fork holders. Popular options include a 3 or 4 drawer tool box and fold down storage brackets for the heavy duty tire lift. You can lock or unlock your compartments with a click of a button as the chrome double action door latches are equipped with a key fob remote.

## BODY SPECIFICATIONS

Model	Standard Body Configuration	Additional Body Configurations
4024	138" C.A.	156, 182" C.A.
5130	156" C.A.	182", 206", 230" C.A.
5230	156" C.B.	180" / 204" C.B.
7035	156" C.B.	180" / 204" C.B.
9055	156" C.B.	180" / 204" C.B.
SP 850-XP	156" C.B.	180"

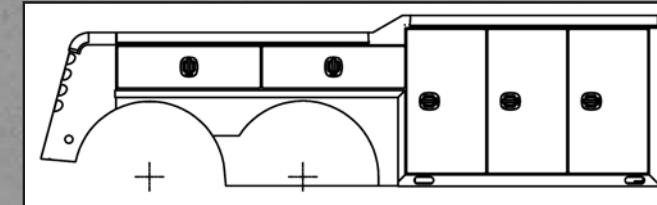

To provide you with the strength and durability you need for your toughest tows while still providing the lowest profile stinger to get under those extremely low vehicles, Century offers the Low Rider Underlift. Constructed using four plate high tensile steel design and available on both the 7035 & 9055. The "Street" Low Rider provides you with the standard reach while the "Coach" Low Rider provides additional reach to haul those difficult pumpers, packers, coaches, and fire trucks.



5230

The 5230 is designed to be the ideal unit for towing when scale weight is an issue. The 5230 provides 128" of underlift reach to easily handle most vehicles and is standard with Century's weight-saving aluminum body. A 30-ton recovery boom and 25,000 lb. winches completes this popular package.



7035

(PolyBilt Body Option shown)

The 7035 is Century's most popular heavy-duty unit. The underlift provides 128" of reach and is designed to scale in most situations. The 35-Ton recovery boom and dual 35,000 lb. winches allows the 7035 to tackle the toughest lifting and recovery jobs, making it extremely versatile for heavy-duty towing and recovery.

The optional aluminum tubular pylon is available in several styles and sizes. The pylons are constructed to provide a rugged structural platform for your warning and working lights with a stylish custom appearance.



The diagonally opposed outriggers provide superior side and rear stability. The multi-position feet provide you with your choice of a flat pad or a spade with a replaceable grater blade. Optional "D" rings are available for low pull situations. An aluminum heel plate is also standard on the bottom side of the underlift to help protect your paint or lettering.



For even more stability in side pull situations, the rear outriggers are available with hydraulic extendable feet. The optional outriggers also include a flip down rear spade along with the flat pad that can be converted to a spade for side pulls.



9055

The 9055 is Century's largest capacity integrated towing and recovery unit. With a 50-ton recovery boom, with an optional third stage, and dual 50,000 lb. winches, the 9055 is ideal for heavy recovery work along with the ability to tow a wide variety of vehicles from mixers and packers through buses with its 138" of underlift reach.



SP 850-XP

The SP 850-XP, available on the 7035 and 9055, combines the finest European technology with North America's most popular heavy-duty units. The hydraulic pivoting stiff legs and additional 35,000 lb. winches allow the operator much more power and flexibility in tough recovery situations including side pulls without shutting down roadways.



The Standard dual rear control stations provide smooth variable flow control of the functions at your fingertips. Dual pressure gauges, air winch clutch release switches, hour meter and air regulators are conveniently located in the polycarbonate control panel on driver side. Optional LED backlit control legends are available.

Standard equipment includes 9 sets of cast forks, pivoting spring lift adaptors, chain hook end cups and low profile cast forks holders to provide you with the attachments you need for most towing applications. Century provides the largest choice of standard and optional forks and attachments in the industry.



The PolyBilt body option provides a rugged durable design that has gone through years of field testing. The boxes feature roll up aluminum doors with remote lock/unlock, adjustable shelves and built in storage for your forks and popular attachments. The PolyBilt body is ideal for harsh northern environments to provide superior protection from rust and corrosion caused by road chemicals.

Above units show several popular body and equipment options.



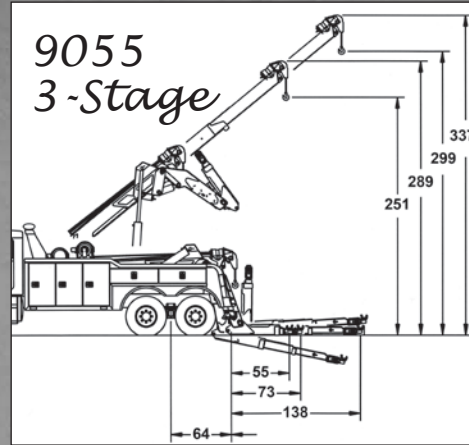
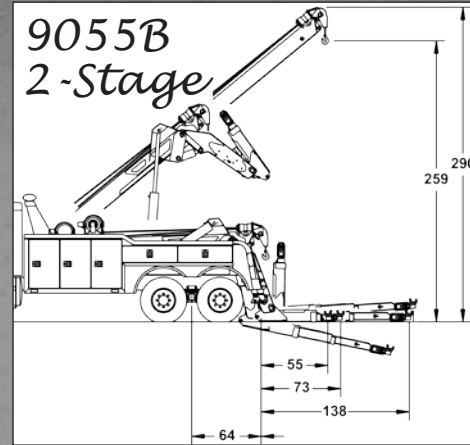
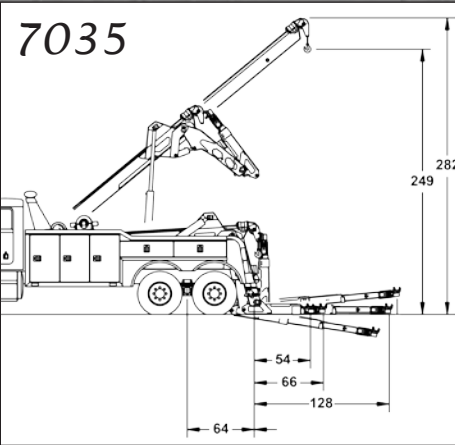
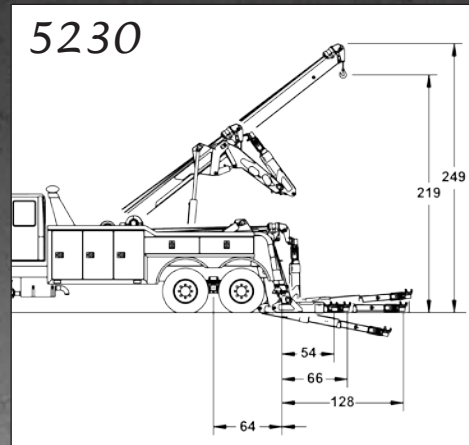
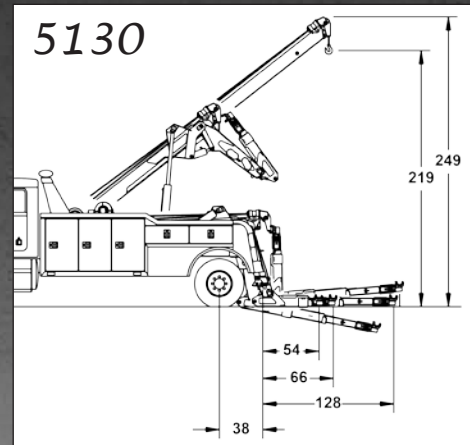
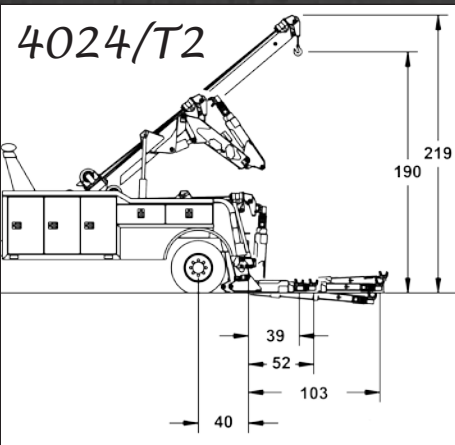

# CENTURY® HEAVY DUTY INTEGRATED

## BOOM SPECIFICATIONS

Model	Boom Structural Rating (S.A.E.)		Boom Angle	Maximum Hook Height (inches)	Hydraulic Boom Extension (inches)
	Retracted 30°	Extended 30°			
4024	20 ton	15,000 lbs.	40°	190"	96"
5130	25 ton	16,000 lbs.	39°	219"	120"
5230	30 ton	16,000 lbs.	39°	219"	120"
7035	35 ton	22,000 lbs.	40°	249"	130"
9055B	50 ton	30,000 lbs.	39°	259"	144"
9055 (3 Stage)	50 ton	18,000 lbs.	39°	299"	216"

## UNDERLIFT SPECIFICATIONS

Model	Extended Underlift	Retracted Underlift	Tilt Arc	Tow Rating
4024	12,000 lbs. @ 103"	24,000 lbs. @ 39"	8°	50,000 lbs.
5130 / 5230	16,000 lbs. @ 128"	35,000 lbs. @ 54"	20°	80,000 lbs.
7035* Low Rider	16,000 lbs. @ 128"	35,000 lbs. @ 54"	20°	80,000 lbs.
7035 Coach Low Rider	16,000 lbs. @ 138"	35,000 lbs. @ 59"	20°	80,000 lbs.
9055* Low Rider	17,000 lbs. @ 138"	55,000 lbs. @ 55"	17°	80,000 lbs.
9055 Coach Low Rider	17,000 lbs. @ 160"	55,000 lbs. @ 62"	17°	80,000 lbs.

\*Based on a 42" chassis frame height. Retracted distance taken with fork holders flipped inward.  
\*Measurement & Specifications include the Optional "Street" Lowrider

## WINCH SPECIFICATIONS

Model	Winch Capacity	Winch Type	Cable Specifications
4024	20,000 lbs.	Dual Planetary Winch	9/16" x 175' L.W.R.C.
5130	25,000 lbs.	Dual Planetary Winch (2 Speed)	5/8" x 200' L.W.R.C.
5230	25,000 lbs.	Dual Planetary Winch (2 Speed)	5/8" x 200' L.W.R.C.
7035	35,000 lbs.	Dual Planetary Winch (2 Speed)	3/4" x 200' L.W.R.C.
9055	50,000 lbs.	Dual Planetary Winch (2 Speed)	3/4" x 250' L.W.R.C.
SP 850-XP	35,000 lbs.	Dual Planetary Winch (2 Speed)	5/8" x 200' L.W.R.C.

## CHASSIS RECOMMENDATIONS

Model	Front Axle (lbs.)	Rear Axle (lbs.)	Clear C.A. / C.B.	After Frame from Center of Rear Axle	R.B.M. (in./lbs.)
4024	10,000	21,000	138"	42"	1,200,000
5130	12,000	21,000	156"	40"	1,650,000
5230	13,200	40,000	156"	40"	2,250,000
7035	13,200	40,000	156"	40"	2,250,000
7035 (SP 850-XP)	14,600	40,000	204"	40"	3,000,000
9055	14,600	40,000	156"	40"	3,000,000
9055 (SP 850-XP)	20,000	40,000	204"	40"	3,500,000

## STANDARD FEATURES

- Dual Control Stations
- Pressure Gauges & Hour Meter
- Hydraulic Pump
- Diagonal Hydraulic Rear Spades w/Flipper Feet
- Safety Chains in Rear Pockets
- Air & Electric Hook Ups
- MVEC Power Distribution System & Switch Panel
- MMO Interface (7035/9055 only)
- Tailboard D-Rings (7035/9055 only)

## BOOM FEATURES

- Power Elevation & Power Extension
- 360° Sheave Head
- Cable Tie Backs
- Cable Tensioners
- Winch Air Free Spool
- Dual 2-Speed Planetary Winches (N/A for 4024)

## UNDERLIFT FEATURES

- Power Tilt & Power Extension
- Hydraulic Fold
- 3-Stage Design
- Low Profile 70° Pivoting Heavy Duty Fabricated Cross Bar
- Low Profile Fork Holders
- Pivoting Spring Lift Adaptors
- Chain Hook End Caps
- 14 FXN Wireless Remote Control with Charging/Docking Station (7035/9055 only) (8 FXN on 4024/5130/5230)
- 9 Sets of Cast Steel Forks:
  - 3" Short 4.5" Short Grab Axle Fork
  - 3" Medium 4.5" Medium 6" Short Offset
  - 3" Tall 4.5" Tall 6" Medium Rear Axle Fork

All ratings are based on structural factors only, not vehicle capacities or capabilities. Specifications shown are approximations and may vary depending on chassis selected. Miller Industries Towing Equipment Inc. reserves the right to change or modify product and or specifications without notice or obligation. Some equipment shown is optional.

\*All Recommendations are minimums. Heavier specifications may be required depending on chassis and equipment weight.

The outside frame rails of chassis extending behind the cab must be free of fuel tanks, air tanks, battery boxes, etc.

## BODY FEATURES

- 96" Wide Aluminum Modular Body
- Rubber Mounting Isolators
- LED Body Lighting
- LED Tool Compartment Lighting
- Chrome Double Action Latches with Remote Lock/Unlock
- Gas Door Shocks
- Adjustable Shelves
- Lift Fork Storage
- Chain Storage
- Tailboard Fork & Chain Storage
- Aluminum Tread-Plate Walkway
- Mud Flaps

## OPTIONAL FEATURES

- Air Shift PTO
- Tailgate Underlift Controls
- Additional Body Lengths
- Crossover Tunnel Box
- PolyBilt Body Option
- MMO Interface (STD 7035/9055)
- LED Body Strip Lamps
- Body Lighting Strobe Kit
- Aluminum Dress-Up Kits
- Aluminum Tubular Light Pylon
- 3 and 4 Drawer Tool Boxes
- Offset Fork Holder Extensions
- Fork Riser Brackets
- Chain Hook Slide Adapter
- Pintle Hook Attachment
- 5th Wheel Plate
- King Pin Attachment
- Trailer Ball Adapter
- Heavy Duty Tire Lift (13K)
- XHD Tire Lift (25K)
- Tire Lift Storage Brackets
- Chain Washdown Compartment
- Additional Lift Forks
- Ground Penetrating Plate
- Backlit Controls
- Low Pull "D" Ring Kit
- Flipper Feet Grater Blades
- Chain Package
- Endless Loop Sling Package
- Spreader Bars
- Screw Pin Shackles Package
- Chain Shackle
- Snatch Block Storage Bar or Rack
- Light Bar
- Work & Hook-Up Lighting
- Xenon Boom Lights
- Swivel Work Lights
- Coach LowRider Underlift (7035 & 9055)
- PTO Override
- Wireless Wide Load Light Bar
- Dual Rear Camera & Monitor
- Hydraulic Extendable Rear Outriggers
- 24", 30", 36" or 48" Saddle Tunnel Box
- Shelf Kit for 30", 36" & 48" Tunnel Boxes
- "D" Rings (Tailboard Mount, Standard on the 7035 & 9055)
- 9055-B (2-Stage Boom, 35K Winches, MMO Delete)

# CENTURY®



7035



9055  
3-Stage

(Hydraulic Extendable Rear Jacks shown)



**Miller**  
INDUSTRIES  
©2013 Miller Industries Towing Equipment Inc.  
All Rights Reserved.

**CENTURY®**

8503 Hilltop Drive • Ooltewah, TN 37363  
800-292-0330 • 423-238-4171  
FAX 423-238-5371 • www.MillerInd.com

DISTRIBUTED BY: