

CHEVRON



OWNER'S MANUAL

SERIES 30

INSTALLATION, OPERATION, MAINTENANCE & PARTS

**NOTE: MANUAL including SPECIFICATIONS, subject to change without notice.
All ratings specified are based on structural factors only,
not vehicle capacities or capabilities.**

CHEVRON

Carriers & Wreckers
7320 W. Market Street
Mercer, PA 16137
Phone (724) 981-7500 • FAX (724) 981-4425
Toll Free (800) 886-6400
<http://www.chevroninc.com>

PART NO. OMC3000

LIMITED WARRANTY

CHEVRON, INC., ("Chevron"), warrants to the original purchaser that each new Chevron product will be free from defects in material and workmanship for a period of twelve (12) months from date placed in service. The purchaser must promptly notify Chevron in writing of any failure in material or workmanship. In no event shall Chevron accept such notification later than twelve (12) months from date placed in service.

Chevron's obligation under this warranty, statutory or otherwise, is limited to the repair or replacement at the Chevron factory, or at a point designated by Chevron, of such part or parts as shall appear upon inspection by Chevron to be defective in material or workmanship. New or remanufactured parts will be used for any replacement at Chevron's option. This warranty is not transferable. This warranty does not obligate Chevron to bear the cost of labor or transportation charges in connection with the repair or replacement of any parts found to be defective, nor shall it apply to a product upon which repairs or alterations have been made unless authorized by Chevron.

EXCEPT AS EXPRESSLY SET FORTH IN THIS WARRANTY, CHEVRON MAKES NO OTHER WARRANTY, EXPRESS OR IMPLIED, AND HEREBY DISCLAIMS ALL OTHER WARRANTIES INCLUDING, BUT NOT LIMITED TO, THE IMPLIED WARRANTIES OF MERCHANTABILITY AND FITNESS FOR A PARTICULAR PURPOSE. Chevron shall in no event be liable for claimed downtime, claimed loss of profits or good will, or any other special, incidental, indirect, or consequential damages concerning or relating to any product or parts, whether based on negligence, strict liability, breach of contract, breach of warranty, misrepresentation or any other legal theory, regardless of whether the loss resulted from any general or particular requirement which Chevron knew or had reason to know about at the time of sale.

CHEVRON MAKES NO WARRANTY, EXPRESS OR IMPLIED, AS TO THE FINISHED PRODUCTS MANUFACTURED OR SUPPLIED BY ANOTHER MANUFACTURER AND SUPPLIED BY CHEVRON TO PURCHASER, including, but not limited to, any vehicle to which a Chevron product may be affixed or any accessories or wire rope, and CHEVRON EXPRESSLY DISCLAIMS ANY IMPLIED WARRANTIES OR MERCHANTABILITY OR FITNESS FOR A PARTICULAR PURPOSE AS TO SUCH EQUIPMENT OR PRODUCTS. This language shall in no way affect or diminish the rights of the purchaser to rely on such warranties as are extended by such manufacturers or suppliers. Chevron shall, to the extent permitted under applicable law, pass on to the purchaser such manufacturer's or seller's warranty.

Chevron, whose policy is one of continuous improvement, reserves the right to improve its products through changes in design or materials as it may deem desirable without being obligated to incorporate such changes in products previously sold. This warranty is not intended to cover or include the following items, which are set forth by way of example and not limitation:

- A. Normal deterioration of trim, paint, lettering, and appearance items due to wear or exposure to weather, road conditions, road treatments, etc.
- B. Any damage or defect due to accident, misuse, abuse, operation exceeding rated loads, improper or unauthorized repairs, failure to provide reasonable and necessary maintenance, or uses of which the equipment was not designed or intended.
- C. Alterations or modifications that affect performance, operations or reliability.
- D. Normal maintenance parts including, but not limited to, wear pads, bushings, wire rope, mudflaps, fenderettes, light bulbs, hydraulic oil, filters, and tow sling belts.

IT IS EXPRESSLY UNDERSTOOD THAT CHEVRON MAKES NO IMPLIED WARRANTY THAT CHEVRON PRODUCTS SHALL BE FIT FOR THE PURPOSE OF LIFTING OR MOVING PEOPLE OR FOR ANY OTHER IMPROPER USE.

Section V - PARTS
SERIES 30 STEEL BODY

REF	PART #	DESCRIPTION	QPU
1	93200R	RED MARKER LIGHT 2-1/2 LED	2
2	93200A	AMBER MRAKER LIGHT 2-1/2 LED	8
3	93150	MARKER LIGHT GROMMET 2-1/2	10
4	716215L	WARN 20XL WINCH GUARD - LEFT	1
5	716215R	WARN 20XL WINCH GUARD - RIGHT	1
6	A90161	ROLLER GUIDE	1
7	7112014	WARN SERIES 20XL PLANETARY WINCH	1
8	33414	LOWER SLIDE RAIL WEAR PAD	4
9	83310	NUT 1/2-13 UNC ZINC PLATED	24
10	81439	BOLT 1/2-13 UNC x 1-3/4 ZINC PLATED	24
11	346071F	REMOVABLE RAIL - 71.5 IN. FRONT	2
12	346071M	REMOVABLE RAIL - 71.5 IN. MIDDLE	4
13	346064	REMOVABLE RAIL REAR	2
14	84712	LYNCH PIN - 7/16 x 1-15/16	6

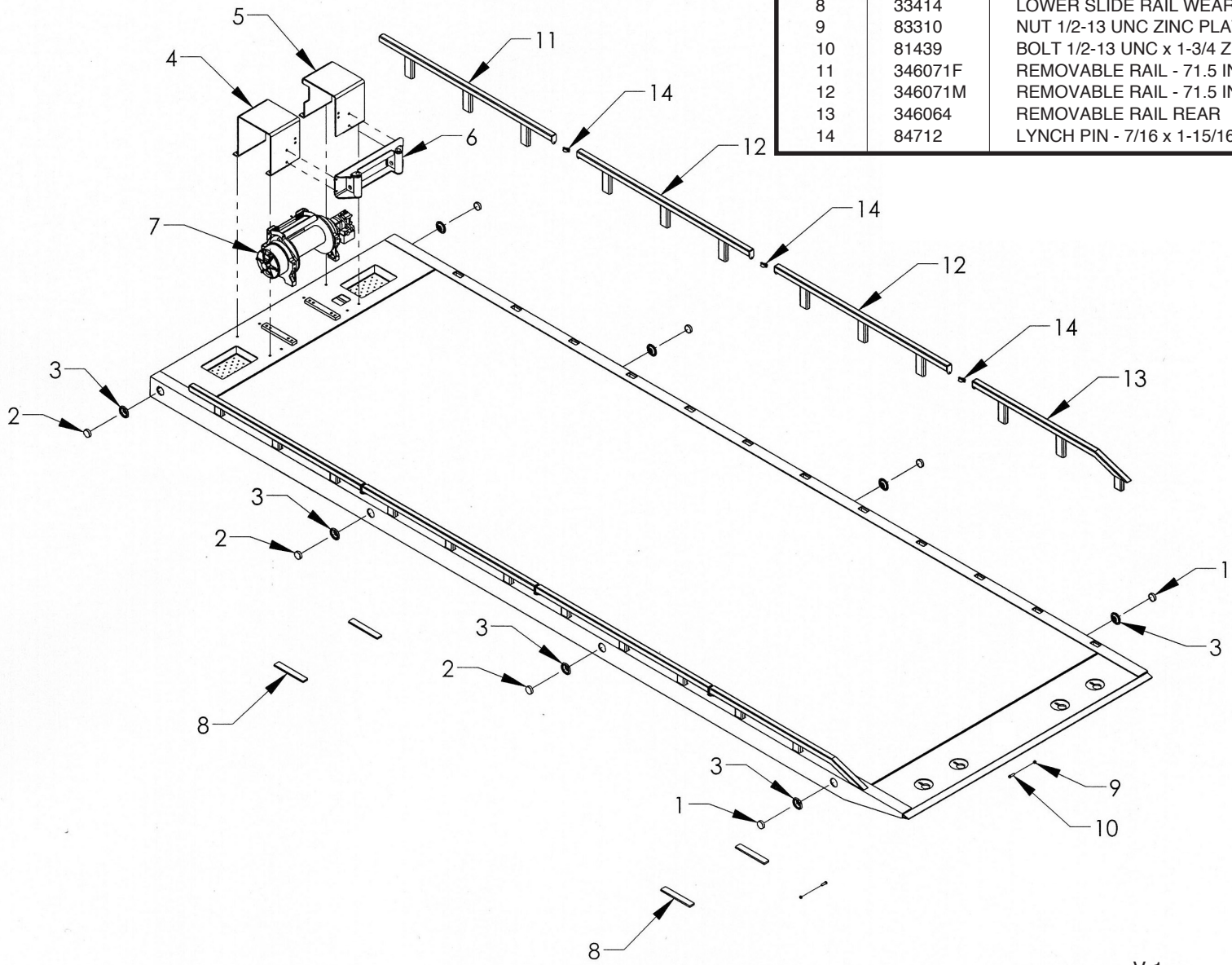

Section V - PARTS
SERIES 30 WHEEL LIFT SUBFRAME

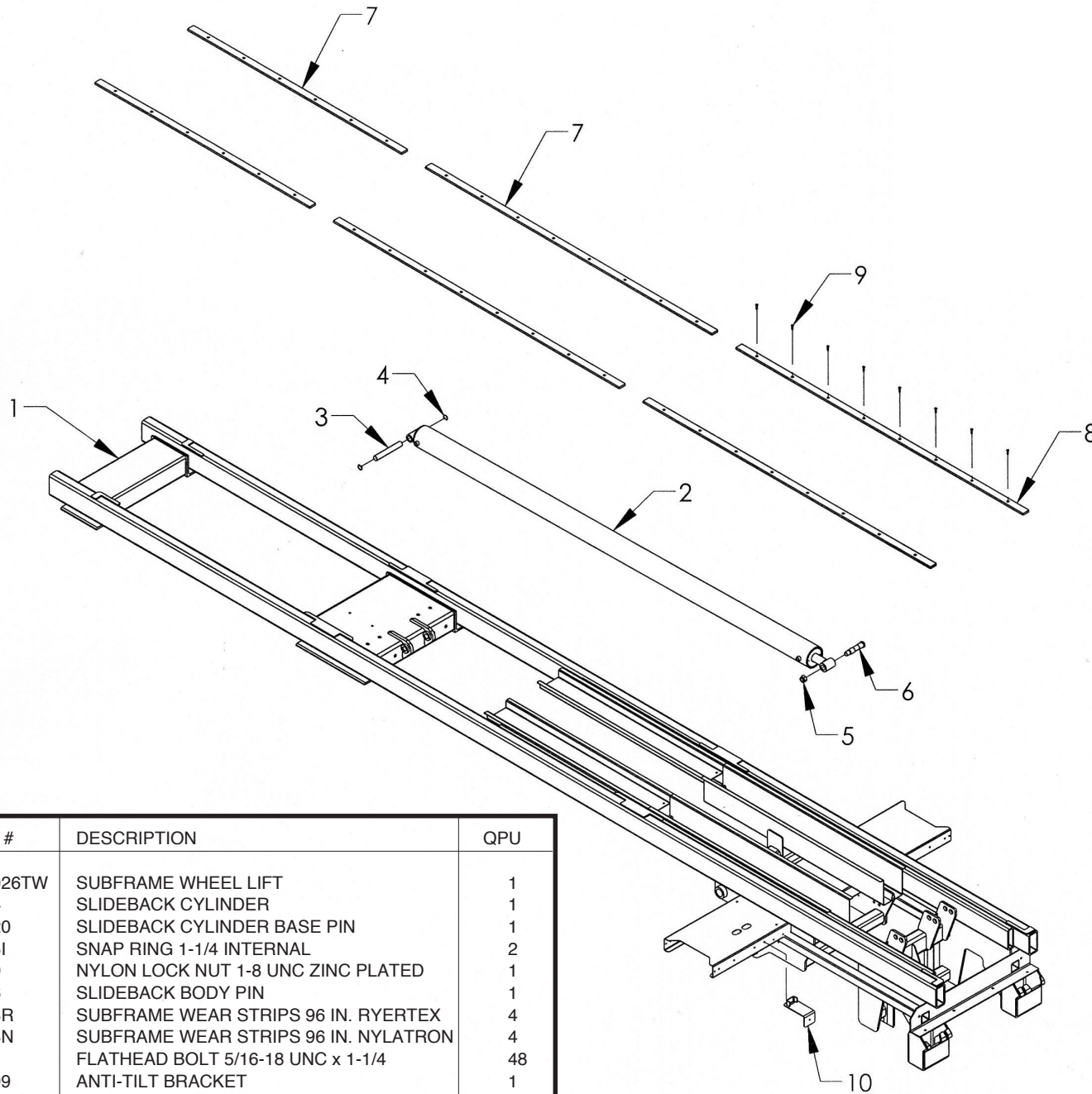

REF	PART #	DESCRIPTION	QPU
1	1033026TW	SUBFRAME WHEEL LIFT	1
2	72104	SLIDEBACK CYLINDER	1
3	133020	SLIDEBACK CYLINDER BASE PIN	1
4	86125I	SNAP RING 1-1/4 INTERNAL	2
5	83730	NYLON LOCK NUT 1-8 UNC ZINC PLATED	1
6	32116	SLIDEBACK BODY PIN	1
7	33308R	SUBFRAME WEAR STRIPS 96 IN. RYERTEX	4
8	33308N	SUBFRAME WEAR STRIPS 96 IN. NYLATRON	4
9	81121	FLATHEAD BOLT 5/16-18 UNC x 1-1/4	48
10	181409	ANTI-TILT BRACKET	1

Section V - PARTS

TILT CYLINDER COMPONENTS

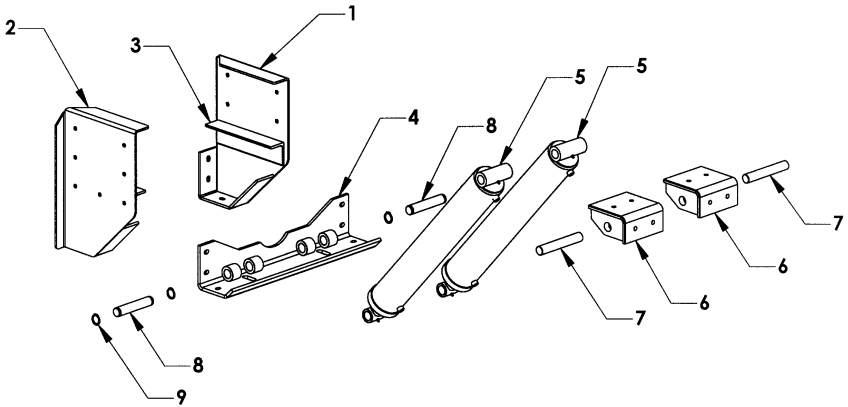

REF	PART #	DESCRIPTION	QPU
1	1A510R	TILT CYLINDER SADDLE-RIGHT	1
2	1A510L	TILT CYLINDER SADDLE-LEFT	1
3	1A514	UNDERFRAME SUPPORT ANGLE	2
4	1A530	CONNECTING ANGLE	1
5	72116	TILT CYLINDER	2
6	13430	TILT CYLINDER FOOT	2
7	13435	TILT CYLINDER BASE PIN 1.480 x 9.25	2
8	1A534	TILT CYLINDER ROD PIN 1.480 x 7.875	2
9	86150E	RETAINING RING 7200-150	4

Section V - PARTS

BODY LOCK

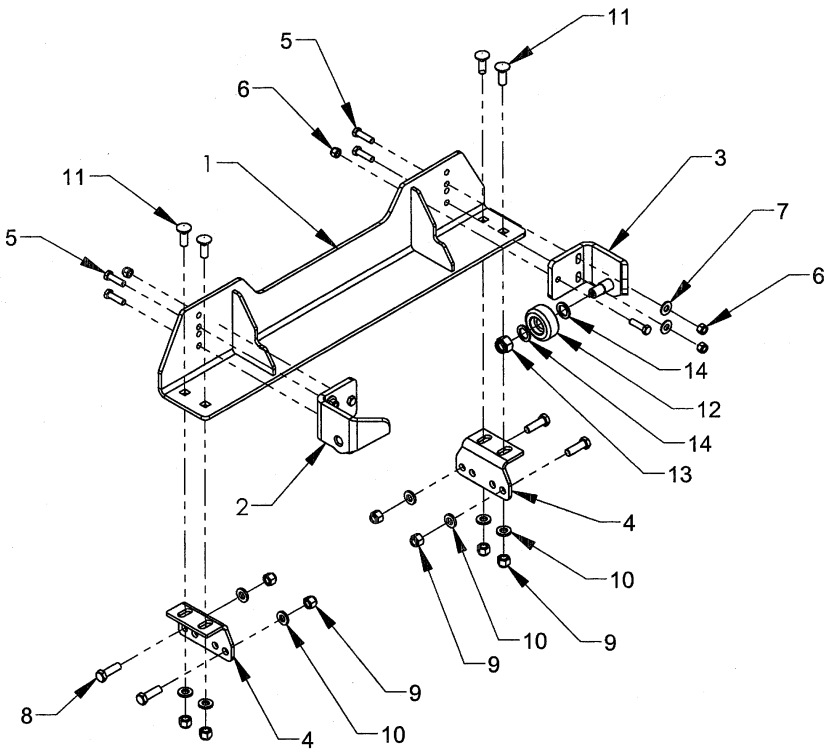

REF	PART #	DESCRIPTION	QPU
1	364002	BODY LOCK WELDMENT	1
2	36315L	BODY LOCK HOLD-DOWN (LEFT)	1
3	36315R	BODY LOCK HOLD-DOWN (RIGHT)	1
4	364062	MOUNTING BRACKET	2
5	81438	BOLT, HHCS 1/2-20 x 1-3/4	6
6	83324	NYLON LOCK NUT, 1/2-20 ZP	6
7	82310	FLAT WASHER, 1/2 ZP	4
8	81520	BOLT, HHCS 5/8-11 x 2 ZP GRADE 5	4
9	83411	NYLON LOCK NUT, 5/8-11 ZP	4
10	82410	FLAT WASHER, 5/8 ZP	8
11	81517	CARRIAGE BOLT, 5/8-11 x 1-3/4 ZP GRADE 5	4
12	36310	HOLD-DOWN WHEEL	2
13	83610	NYLON LOCK NUT, 7/8-14 ZP	2
14	82710	FLAT WASHER 1 ID x 1-1/2 OD	4

Section V - PARTS DIRECT MOUNT PUMP

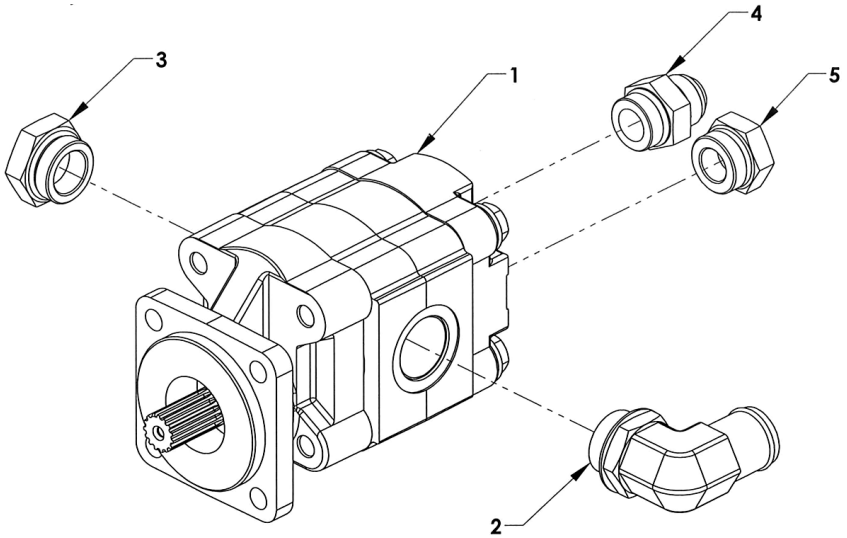

REF	PART #	DESCRIPTION	QPU
1	78006	PUMP-24 GPM (SAE 4 BOLT FLANGE)	1
2	77C92	1-1/4 x 90 M-M O-RING x 1-1/2 NIPPLE	1
3	77620	1-1/4 O-RING PLUG 900598-20	1
4	779A7	1 O-RING x 1 JICF 202702 - 16 x 16	1
5	77616	1 O-RING PLUG 900598-16	1

Section V - PARTS

CONTROL COMPONENTS

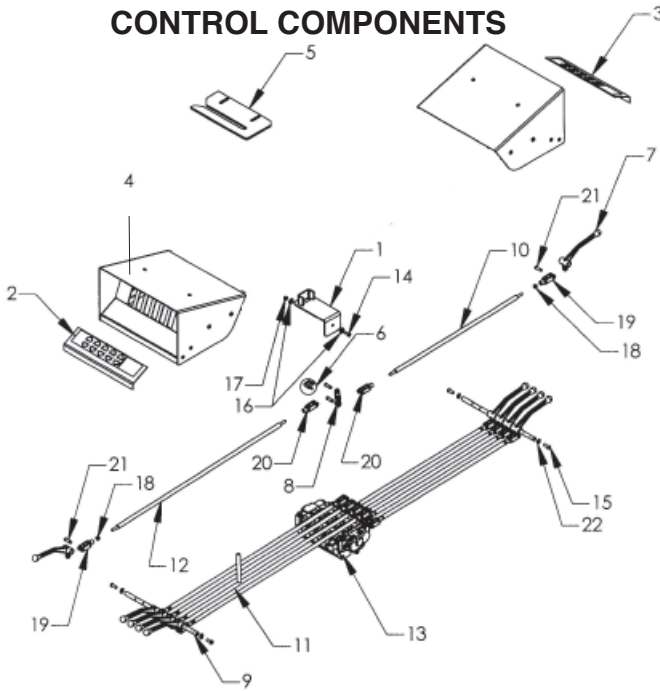

REF	PART #	DESCRIPTION	QPU
1	181409	ANTI-TILT ROD GUIDE	1
2	18212L	CONTROL PANEL I.D. PLATE (DRIVER SIDE)	1
3	18212R	CONTROL PANEL I.D. PLATE (PASS. SIDE)	1
4	18274KL	HOOD KIT - LEFT (PANEL, HOOD, BOLTS, NUTS)	1
	18274KR	HOOD KIT - RIGHT (PANEL, HOOD, BOLTS, NUTS)	1
5	33813	ANTI-TILT PLATE	1
6	7A010	PIN & LINK ASSEMBLY	5
7	7A111	CONTROL HANDLE	10
8	7A121	BELL CRANK	5
9	7A5752	HANDLE CROSS ROD	2
10	7A527A	CONTROL ROD 27-1/4	5
11	7A536A	ANTI-TILT CONTROL ROD 36-1/2	1
12	7A537A	CONTROL ROD 36-1/2	4
13	74115	CONTROL VALVE - 5 SPOOL	1
14	81110	BOLT 5/16-18 UNC x 7/8	1
15	812A9	BOLT 3/8-16 UNC x 1 BUTTON HEAD STAINLES	4
16	82110	FLAT WASHER 5/16	2
17	83125	NUT 5/16-18 UNC NYLON LOCK	1
18	83215	NUT 3/8-24 UNF	10
19	84530	CLEVIS 3/8-24 UNF RIGHT HAND THREAD	10
20	84540	CLEVIS 3/8-24 UNF LEFT HAND THREAD	10
21	84620	CLEVIS PIN 3/8	20
22	86062E	SNAP-RING 5/8 EXTERNAL	4

Section V - PARTS CONTROL HOOD

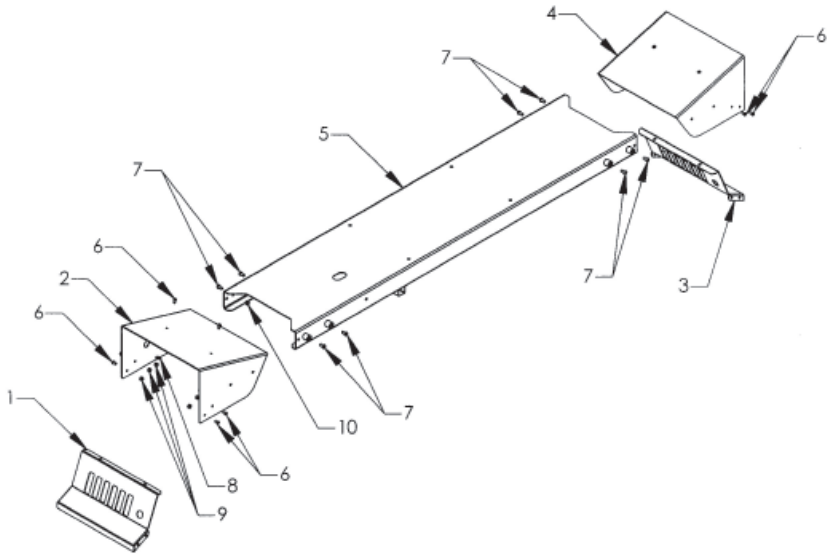

REF	PART #	DESCRIPTION	QPU
1	18126L	CONTROL PANEL - LEFT	1
2	181274L	CONTROL HOOD - LEFT	1
	181274KL	HOOD KIT - LEFT (PANEL, HOOD, BOLTS, NUTS)	
3	18126R	CONTROL PANEL - RIGHT	1
4	181274R	CONTROL HOOD - RIGHT	1
	181274KR	HOOD KIT - RIGHT (PANEL, HOOD, BOLTS, NUTS)	
5	181283W	CONTROL ARM WELDMENT	1
6	811A6	BOLT 5/16-18 UNC x 5/8 BUTTON HEAD STAINLES	12
7	812A7	BOLT 3/8-16 UNC x 3/4 BUTTON HEAD STAINLESS	8
8	82110	FLAT WASHER 5/16	4
9	83125	NUT 5/16-18 UNC NYLON LOCK	12
10	83215	NUT 3/8-16 UNC NYLON LOCK	4

Section V - PARTS

HYDRAULIC STABILIZER COMPONENTS

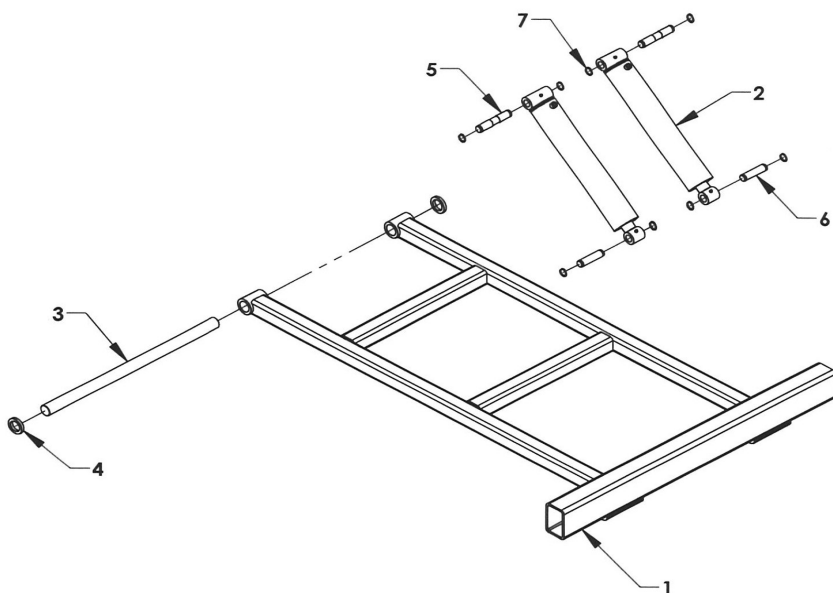

REF	PART #	DESCRIPTION	QPU
1	163730	HYDRAULIC STABILIZER WELDMENT	1
2	72118	STABILIZER CYLINDER - SHORT 25-1/8	2
	721182	STABILIZER CYLINDER - LONG 29-5/8	2
3	1634030	STABILIZER PIVOT PIN	1
4	16341	PIVOT PIN WELD-ON RING	2
5	16363	CYLINDER BASE PIN 1.230 x 6-7/8	2
6	16362	CYLINDER ROD PIN 1.230 x 5	2
7	86125E	SNAP-RING 1-1/4 EXTERNAL	8

Section V - PARTS UNDERLIFT COMPONENTS

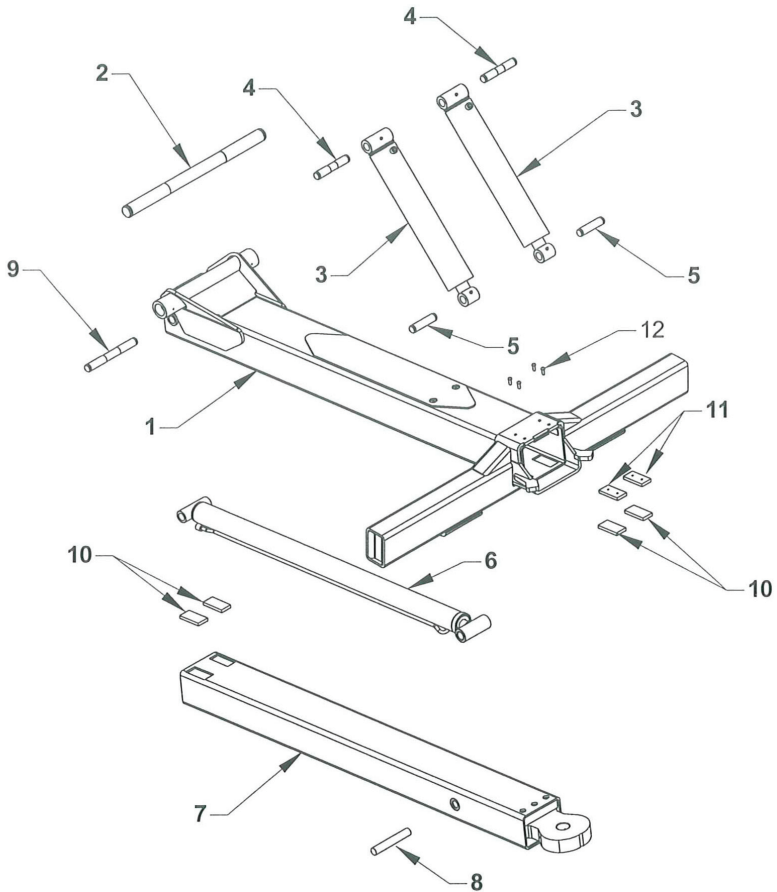

REF	PART #	DESCRIPTION	QPU
1	10261	OUTER UNDERLIFT BOOM WELDMENT	1
2	143122	UNDERLIFT PIVOT PIN SRG 1.975 x 27.50	1
3	72118	SHORT STABILIZER CYLINDER (28.125 CTC)(LGC)	2
	721182	LONG STABILIZER CYLINDER (29.625 CTC)	2
4	16363	CYLINDER BASE PIN SRG 1.230 x 6.688	2
5	16362	CYLINDER ROD PIN 1.230 x 5.00	2
6	7212730	UNDERLIFT EXTENSION CYLINDER	1
7	10262	UNDERLIFT BOOM TUBE-INNER	1
8	14314	EXTENSION CYLINDER ROD PIN 1.230 x 7-5/8	1
9	14313	EXTENSION CYLINDER BASE PIN SRG 1.230 x 10-1/2	1
10	63595	NYLATRON WEAR PAD 1/2 x 2 x 4	4
11	63595H	NYLATRON WEAR PAD 1/2 x 2 x 4 TAPPED	2
12	812A8	3/8-16 x 1 BUTTON HEAD BOLT	4

Section V - PARTS

UNDERLIFT ATTACHMENTS

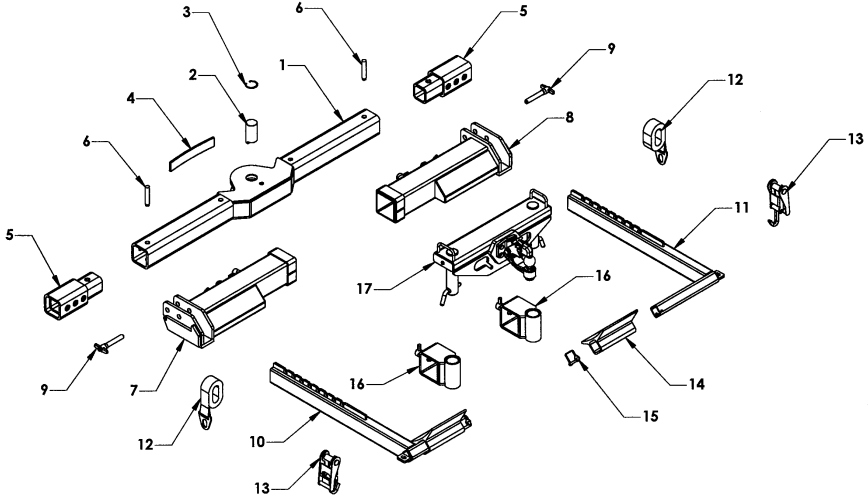

REF	PART #	DESCRIPTION	QPU
1	68510	CROSSBAR	1
2	66430	CROSSBAR PIVOT PIN	1
3	862001	RETAINING RING 2.00 INCH INTERNAL	1
4	65228	CROSSBAR CENTER SPRING	1
5	68530	CROSSBAR EXTENSION	2
6	68545	CROSSBAR EXTENSION PIN	2
7	66260L	WHEEL GRID-LEFT	1
8	66260R	WHEEL GRID-RIGHT	1
9	84922	T-PIN WITH LANYARD 3/4 x 3.5	2
10	66250L	LEFT L-ARM 6000 LB. CAPACITY	1
11	66250R	RIGHT L-ARM 6000 LB. CAPACITY	1
12	65285	WHEEL STRAP	2
13	65280A	RATCHET	2
14	65245	REMOVABLE WHEEL PAN	2
15	84911	WHEEL PAN RETAINING PIN	2
16	66280	SHORT FORK HOLDER (OPTIONAL)	2
17	66370G	PINTLE HITCH ADAPTOR (OPTIONAL)	1

Section V - PARTS

TAIL LIGHT COMPONENTS

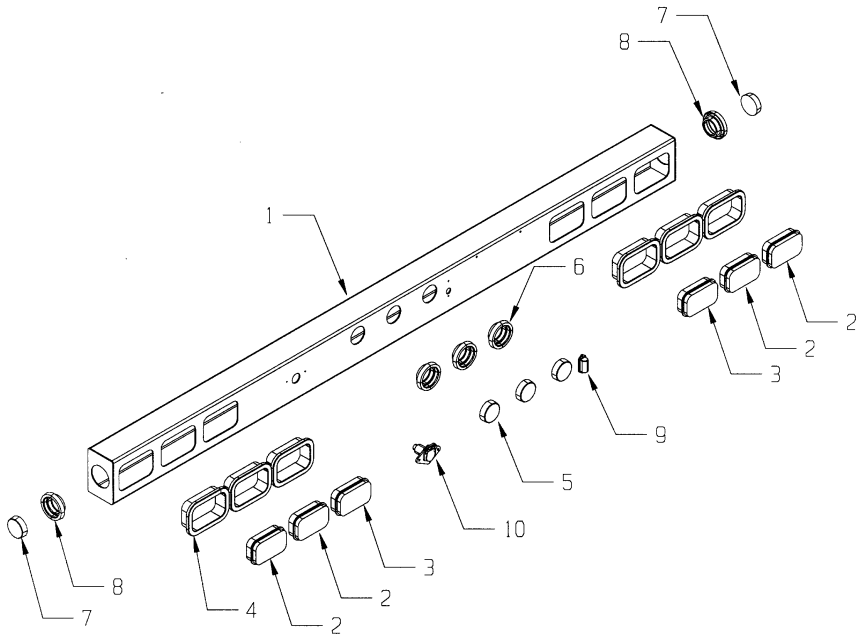

REF	PART #	DESCRIPTION	QPU
1	19500	TAIL LIGHT HOUSING	1
	19510	TAIL LIGHT HOUSING-HITCH	1
2	96500	LIGHT-TAIL, STOP, TURN MODEL 45202R	4
3	95500	LIGHT BACKUP MODEL 45204	2
4	96550	GROMMET MODEL 45700	6
5	94500	ICC LIGHT MODEL 40	3
6	94550	GROMMET MODEL 30	3
7	93100R	MARKER LIGHT MODEL 10	2
8	93150	GROMMET MODEL 10	2
9	97150	LIGHT-LICENSE PLATE	1
10	98400	TOW LIGHT PLUG-4 PRONG	1
	98600	TOW LIGHT PLUG-6 PRONG	1

Section V - PARTS

MUDFLAP COMPONENTS

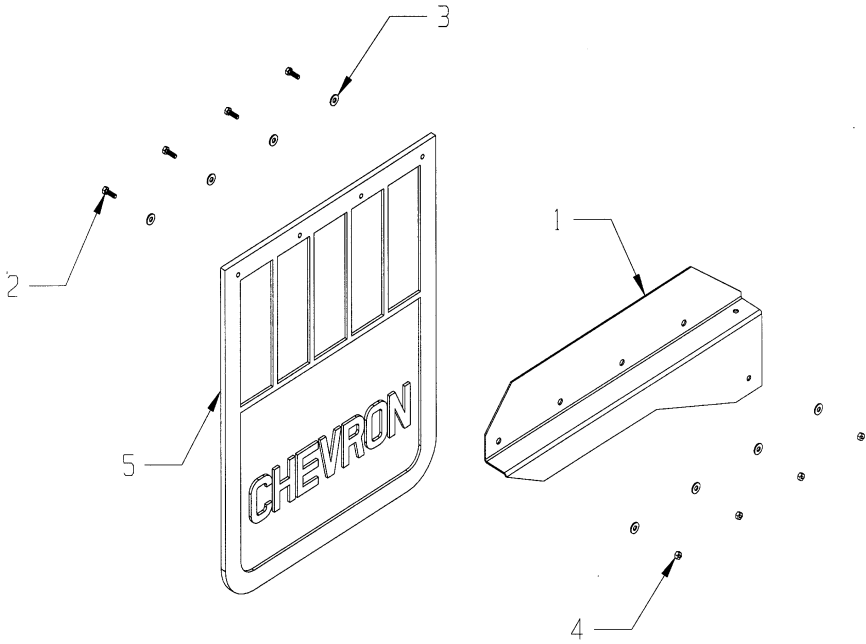

REF	PART #	DESCRIPTION	QPU
1	1235030L	MUDFLAP MOUNTING BRACKET	1
	1235030R	MUDFLAP MOUNTING BRACKET	1
2	81110	5/16 x 1-1/4 BOLT	8
3	82110	5/16 FLAT WASHER	16
4	83125	5/16 NYLON LOCK NUT	8
5	A1030	MUDFLAP 24 x 30	2

Section V - PARTS

33" ALUMINUM TOOLBOX - 377000

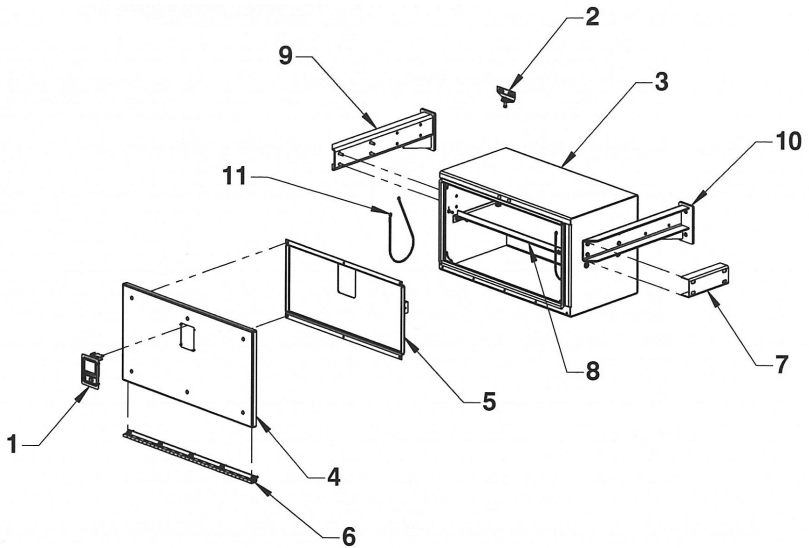

REF	PART #	DESCRIPTION	QPU
1	54658	ROTARY PADDLE LATCH	1
	54657	GASKET FOR PADDLE LATCH	1
	81111	#8-32 X 1/2 STAINLESS ONE WAY SCREW	4
	83111	#8-32 STAINLESS KEPT NUT	4
2	376182	STRIKER PIN MOUNTING PLATE	1
	54659	STRIKER PIN	1
	81115	STAINLESS CARRIAGE BOLT 5/16-18 x 3/4	2
	82110	FLAT WASHER 5/16	4
	82130	LOCK WASHER 5/16	2
	83110	NUT 5/16-18	2
	83125	NYLON LOCK NUT 5/16-18	1
	3	377100W	BOX WELDMENT
4	37741	DOOR WELDMENT	1
	37740	DOOR ASSEMBLY	1
	81100	STAINLESS CARRIAGE BOLT 1/4-20 x 3/4	6
	83105	NYLON LOCK NUT 1/4-20	6
	5	37744	DOOR REINFORCEMENT
6	37735	HINGE	1
	811014	SS SOCKET BUTTON HEAD BOLT 1/4-20 x 7/8	2
	811012	SS SOCKET BUTTON HEAD BOLT 1/4-20 x 3/4	3
	811010	SS SOCKET BUTTON HEAD BOLT 1/4-20 x 5/8	5
	83105	NYLON LOCK NUT 1/4-20	10
	7	37760	TANDEM BOX SPACER CHANNEL (OPTIONAL)
8	37770	SHELF	1
9	37850L	TOOLBOX MOUNTING BRACKET-LEFT	1
10	37850R	TOOLBOX MOUNTING BRACKET-RIGHT	1
11	5A221	LANYARD-21 INCH	2

Section V - PARTS

49" ALUMINUM TOOLBOX - 378000

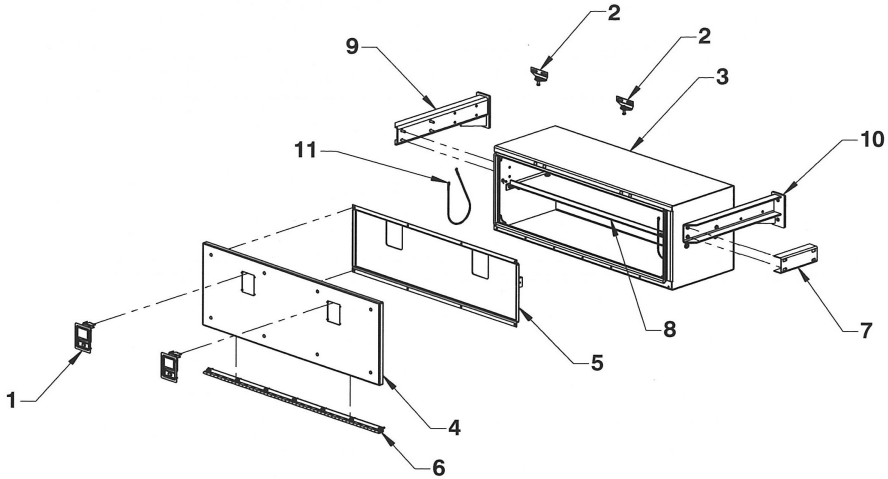

REF	PART #	DESCRIPTION	QPU
1	54658	ROTARY PADDLE LATCH	2
	54657	GASKET FOR PADDLE LATCH	2
	81111	#8-32 X 1/2 STAINLESS ONE WAY SCREW	8
	83111	#8-32 STAINLESS KEPT NUT	8
2	376182	STRIKER PIN MOUNTING PLATE	2
	54659	STRIKER PIN	2
	81115	STAINLESS CARRIAGE BOLT 5/16-18 x 3/4	4
	82110	FLAT WASHER 5/16	8
	82130	LOCK WASHER 5/16	4
	83110	NUT 5/16-18	4
	83125	NYLON LOCK NUT 5/16-18	2
3	378100W	BOX WELDMENT	1
4	37841	DOOR WELDMENT	1
	37840	DOOR ASSEMBLY	1
	81100	STAINLESS CARRIAGE BOLT 1/4-20 x 3/4	8
	83105	NYLON LOCK NUT 1/4-20	8
5	37844	DOOR REINFORCEMENT	1
6	37835	HINGE	1
	811014	SS SOCKET BUTTON HEAD BOLT 1/4-20 x 7/8	2
	811012	SS SOCKET BUTTON HEAD BOLT 1/4-20 x 3/4	5
	811010	SS SOCKET BUTTON HEAD BOLT 1/4-20 x 5/8	7
	83105	NYLON LOCK NUT 1/4-20	14
7	37760	TANDEM BOX SPACER CHANNEL (OPTIONAL)	1
8	37670	SHELF	1
9	37850L	TOOLBOX MOUNTING BRACKET-LEFT	1
10	37850R	TOOLBOX MOUNTING BRACKET-RIGHT	1
11	5A221	LANYARD-21 INCH	2

Section V - PARTS

65" ALUMINUM TOOLBOX - 379000

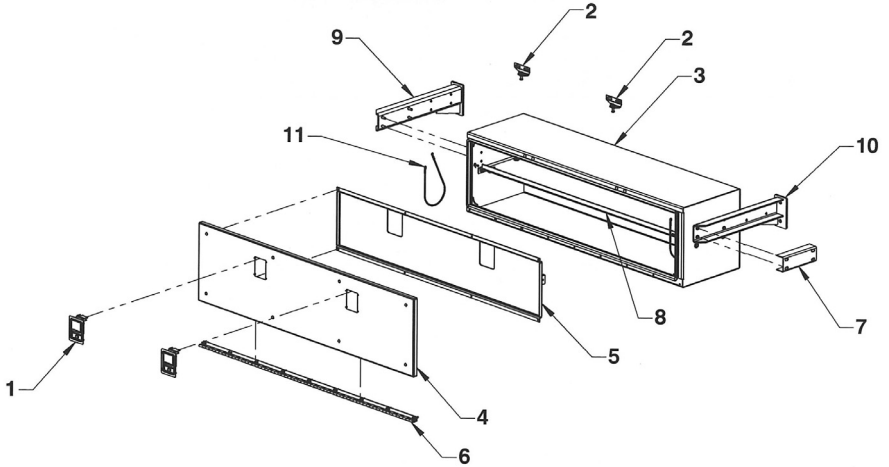

REF	PART #	DESCRIPTION	QPU	
1	54658	ROTARY PADDLE LATCH	2	
	54657	GASKET FOR PADDLE LATCH	2	
	81111	#8-32 X 1/2 STAINLESS ONE WAY SCREW	8	
	83111	#8-32 STAINLESS KEPT NUT	8	
	2	376182	STRIKER PIN MOUNTING PLATE	2
2	54659	STRIKER PIN	2	
	81115	STAINLESS CARRIAGE BOLT 5/16-18 x 3/4	4	
	82110	FLAT WASHER 5/16	8	
	82130	LOCK WASHER 5/16	4	
	83110	NUT 5/16-18	4	
	83125	NYLON LOCK NUT 5/16-18	2	
	3	379100W	BOX WELDMENT	1
	4	37941	DOOR WELDMENT	1
37940		DOOR ASSEMBLY	1	
81100		STAINLESS CARRIAGE BOLT 1/4-20 x 3/4	8	
83105		NYLON LOCK NUT 1/4-20	8	
5		37944	DOOR REINFORCEMENT	1
6	37935	HINGE	1	
	811014	SS SOCKET BUTTON HEAD BOLT 1/4-20 x 7/8	2	
	811012	SS SOCKET BUTTON HEAD BOLT 1/4-20 x 3/4	7	
	811010	SS SOCKET BUTTON HEAD BOLT 1/4-20 x 5/8	9	
	83105	NYLON LOCK NUT 1/4-20	18	
7	37760	TANDEM BOX SPACER CHANNEL (OPTIONAL)	1	
8	37970	SHELF	1	
9	37850L	TOOLBOX MOUNTING BRACKET-LEFT	1	
10	37850R	TOOLBOX MOUNTING BRACKET-RIGHT	1	
11	5A221	LANYARD-21 INCH	2	

Section V - PARTS

PINTLE HITCH GROUP

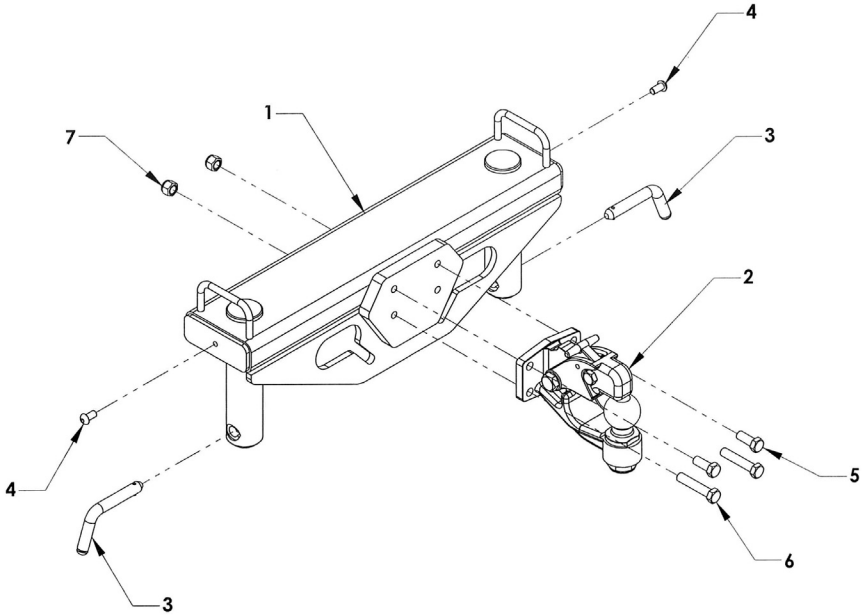

REF	PART #	DESCRIPTION	QPU
	66370G	PINTLE HITCH GROUP	1
1	66370W	PINTLE HITCH WELDMENT	1
2	A3020	TOW BALL PINTLE HITCH	1
3	66378	RETAINING PIN	2
4	812A6	3/8 X 5/8 BUTTON HEAD BOLT	4
	5A220	LANYARD	2
5	81428	BOLT 1/2-13 X 1.25 GRADE 8 SECURE WITH LOCTITE	2
6	81449	BOLT 1/2-13 X 2.5 GRADE 8	2
7	83312	NUT NYLOK 1/2-13	2

Section V - PARTS
RETRACTABLE LADDER

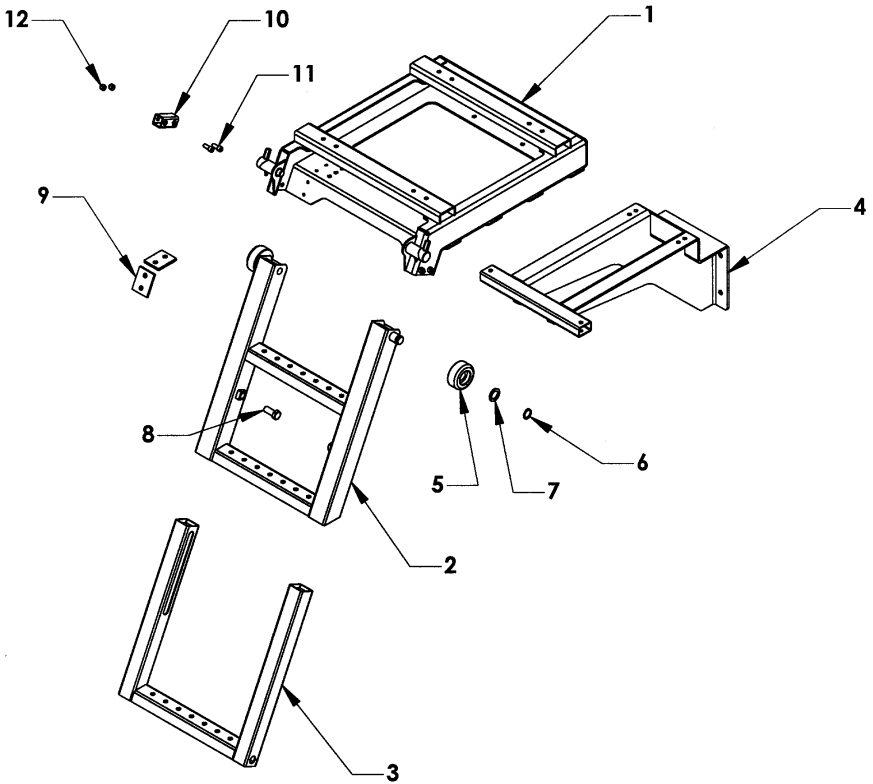

REF	PART #	DESCRIPTION	QPU
	390000	LADDER ASSEMBLY	1
1	391010	LADDER CARRIAGE	1
2	391020	UPPER RUNG ASSEMBLY	1
3	391030	LOWER RUNG ASSEMBLY	1
4	391040	FRAME MOUNTING BRACKET-OPTIONAL	1
5	36310	WHEEL	2
6	86100E	RETAINING RING 1.00 EXTERNAL	2
7	82710	FLAT WASHER 1 x 1.50	2
8	391026	RETAINING BOLT 5/8-11 x 1-1/2	2
9	391018	WEAR PAD	4
10	391015	RETAINING TUBE	2
11	81221	ALLEN HEAD BOLT 3/8-16 x 1	4
12	83211	NYLON LOCK NUT 3/8-16	4